



Electrofusion

Product range 2022



SAFETY FITTINGS

In a rapidly changing world, we offer you security and cost-effectiveness for your networks.

Our connection technology for piping systems is the heart of every supply and disposal system - whatever connection you need, we have the right solution for you.

Gas

We provide you with an extremely secure gas supply network that is particularly economical to operate. You also benefit from comprehensive customer service and training. As a leading supplier of connecting solutions for gas pipes, we provide you with a comprehensive product selection for outstanding results.

Water

We ensure that you can operate the safest water supply network and save time and money. Thanks to high-quality materials, our products have excellent corrosion protection. Therefore avoiding any potential hygiene problems. Our product portfolio includes electrofusion joints, mechanical couplings and tools.

Waste Water

With us you create sewage systems that last for generations. You benefit from the best possible profitability for your investments and extremely low maintenance costs. We offer you a closed system for wastewater that enables safe pipe connections, house connections and shaft connections without root ingrowth.

Tool service by manufacturer

More than 30 years we have been offering complete range of tools and equipment suitable for construction sites as well as service tailored to your requirements.

INFORMATION

Table of Contents • Amendments to the product range
Good to know

FRIALEN®

Safety fittings

FRIAFIT®

Sewage system

FRIATOOLS®

Technical equipment

FRIACLAMP

Table of content

Changes in the 2022 assortment	6	AKHP TL Tapping ball valve Top loading for gas for side tapping under pressure	46
Things worth knowing about safe connection technology with Aliaxis Deutschland	8	KBS Actuating linkage for ball valves	46
FRIALEN safety fittings	13	FRIALEN saddles	47
Things worth knowing about FRIALEN safety fittings and this product range	14	SA Saddle with spigot, SDR 11	47
Future-perspective on hydrogen	16	SAFL Spigot saddle with flange outlet, SDR 11	48
Safety Technology - open-wire technology	17	SA TL Top-loading spigot saddle, SDR 11	48
FRIALEN couplers	18	SA UNI Saddle with outlet spigot Universal SDR 11	49
UB SDR 11 Coupler without inner stop, SDR 11	18	SA VL Vacuum-loading spigot saddle, SDR 11	50
MB SDR 11 Coupler with easily removable inner stop, SDR 11	19	RS Repair Saddle, SDR 11	52
FRIALONG SDR 11 Long coupler with easily removable inner stop, SDR 11	19	RSV Repair and reinforcement saddle, SDR11	52
UB SDR 17 Coupler without inner stop, SDR 17	20	RS TL Repair saddle for top loading, SDR11	53
UB SDR 9 Coupler without inner stop, SDR 9	20	RS VL Vacuum-loading repair saddle SDR 11	54
UB SDR 7,4 Coupler without inner stop, SDR 7.4	21	RW Repair sleeve	54
KM SDR 17 Conical ring coupler, SDR 17	21	FIXBLOC Fixation for absorbing axial thrust and tensile forces	55
MR SDR 11 Reducer, SDR 11	22	SPA Balloon shut off saddle	56
REM SDR 17 Reducer, SDR 17 for Relining	22	SPA TL Balloon shut off saddle top-loading	57
MV SDR 11 Cap, SDR 11	23	SPAK Cap for balloon shut off saddles	57
FRIALEN shapes	24	FRIALEN transition fittings	58
WS11 Elbow 11° with spigot	24	VAM RG Valve tapping saddle with transition HD-PE/gunmetal	58
W30 Elbow 30°	24	VAM RG TL Valve tapping saddle top-loading with HD-PE/Gunmetal adapter	58
W45 Elbow 45°	25	USTR Transition fitting, steel pipe	59
W90 Elbow 90°	26	USTRS Transition fitting, steel pipe, spigot	60
WET Misalignment bridge	26	UFLG Transition fitting HD-PE/copper (spigot fitting)	60
WF Elbow with base unit	27	USTN Transition fitting HD-PE/steel with male thread	61
WFGB BAIO Elbow with base unit	27	USTM Transition fitting HD-PE/steel with female thread	61
TA T-piece with spigot	28	MUN Transition fitting in HD-PE/brass with male thread	62
TA RED T-piece with reduced spigot	29	MUN V2A Transition fitting HD-PE/V2A with male thread	62
T T-piece	30	MUM Transition fitting HD-PE/gunmetal with female thread	63
TGB T-piece BAIO	30	UAM ET Universal transition adaptor HD-PE/brass with free union nut with female thread	63
TFL Flange T-piece	31	WUN 90 90° transition elbow HD-PE/brass with external thread	64
Y Y-piece	32	WUN V2A 90 Transition elbow 90° HD-PE/Stainless steel with male thread	64
YS Y-piece with spigot	32	UAN Universal adaptor HD-PE/brass with male thread and PE pipe socket	65
FRIALEN tapping tees	33	UAM Universal transition adaptor HD-PE/brass with female thread	65
DAV Tapping valve RED SNAP, SDR 11	33	EFL Full faced flange (spigot fitting)	66
DAV Tapping valves Classic, SDR 11	34	FLR Flange reducer	66
DBS Installation kit for tapping valves	34	FRIAFIT sewage system	67
DAV TL Top-loading tapping valve, SDR 11	35	Things worth knowing about FRIAFIT Sewage System and this Product Range	68
DAA Tapping tee RED SNAP, SDR 11	36	Safety Technology - open-wire technology	69
DAA TL Top-loading tapping tee, SDR 11	37	FRIAFIT basic programme	70
DAP Vertical tapping tee, SDR 11	38	AM Coupler without inner stop, SDR 17	70
DK Cap for tapping tees, SDR 11	38	UB SDR 17 Coupler without inner stop, SDR 17	70
GAB Purge stack for venting gas pipes	39	REM SDR 17 Reducer, SDR 17 for Relining	71
FRIALEN valves	40	ASF Shaft lining adapter for prefabricated concrete sewage inspection chambers	71
FRIASTOP M Gas-Stop SENTRI GS by Maxitrol	40	ASFL Shaft lining adapter for sewage inspection chambers L = 250 mm	72
FRIASTOP P Gas-Stop by Pipelife	40	AEM Plug-in coupler for shaft lining adapter	72
MR STOP Gas-Stop SENTRI GS by Maxitrol in Reducer	41	FIXBLOC Fixation for absorbing axial thrust and tensile forces	73
FRIALOC PE shut-off valve without flow losses	42	ASA TL Top-loading sewage saddle	74
FRIALOC PE shut-off valve without flow losses (closing in a clockwise direction)	42	ASA TL KG Top-loading transition saddle	75
FBS Actuating linkage for FRIALOC PE shut-off valves	43	ASA UNI Spigot saddle SDR 17	76
KHP Ball valve for gas	44	ASA VL Vacuum-loading sewage saddle	77
KH Ball valve for gas without flow losses	44	ASA MULTI MS Assembly key	78
KHW Ball valve for water	45	ASA MULTI Connecting spigot to clay and concrete pipes	78
AKHP Tapping ball valve for side tapping gas under pressure	45		

ABM Sewage bend	79	FRIATOOLS scraper tools accessories	100
ABMS Sewage bend (one-side spigot end)	79	FWSGE 3 Replacement blade for scraper tools FWSG 225 (until 2019)	100
AMKG Transition coupler PE-PVC/PP	79	FWSGE 4 Replacement blades for scraper tools FWSG 63 (until 2018)	100
UKG Transition piece PE-PVC/PP	80	FWSGE 5 Replacement blade for scraper tools FWSG 710 L/S and FWSG 900 L	100
USTZ Transition piece PE - clay	80	FWSGE 6 Replacement blade for scraper tools FWSGS 110 and FWSGS 180	100
FRIAFIT additional fittings	81	FWSGE 8 Replacement blades for scraper tools FWSG SE (all types)	100
ABS 15 15° sewage bend (spigot fitting)	81	FWSGE 10 Replacement blades for scraper tools FWSG RA 32 and 40	101
ABS 30 30° sewage bend (spigot fitting)	81	FWSGE 11 Replacement blades for scraper machines FWSG RA 50 and 63	101
ABS 45 45° sewage bend (spigot fitting)	82	FWSGE 12 Replacement blades for scraper tools FWSG XL	101
ABS 90 90° sewage bend (spigot fitting)	82	FWSGE 13 Replacement blades for scraper tools FWSG RA 25	101
ATS 45 Equal branch 45° (spigot fitting)	83	FWSGE 14 Replacement blades for scraper tools FWSG 225 / FWSG 400 (from 2019)	102
ATSR 45 Unequal branch 45° (spigot fitting)	83	FWSGE 15 Replacement blades for scraper tools FWSG 63 (from 2018)	102
ATSRS 45 Unequal branch 45° with off-center outlet (spigot fitting)	84	FWSGE K Replacement blades for scraper chain FWSK	102
ATSRS 90 Unequal branch 90° with off-center outlet (spigot fitting)	84	ALTK FWSG Transport boxes	102
CDE Sewage end cap (spigot fitting)	85	FWZ Hand scraper	103
RES Reducer off-center (spigot fitting)	85	FWZ XL Hand scraper for large pipes	103
FRIATOOLS Technical Equipment	87	FRIATOOLS other tools and installation aids	104
Things worth knowing about FRIATOOLS Technical Equipment and this product range	88	FRIATOP Clamping unit (top loading)	104
The FRIAMAT 7 prime and FRIAMAT 7 basic	89	UNITOP Clamping unit for spigot saddles SA UNI / ASA UNI	104
FRIATOOLS fusion units	90	VACUPUMP Vacuum pump with connection pipes	105
FRIAMAT 7 prime Fusion unit with documentation function	90	PRESSKO Plunger	105
FRIAMAT prime eco Fusion unit with documentation function	90	FWAB Drilling equipment	106
FRIAMAT 7 basic Fusion unit without documentation function	91	FWFIT Clamping and drilling unit for FRIAFIT sewage saddles (ASA TL) and transition saddles (ASA TL KG)	106
FRIAMAT basic eco Fusion unit without documentation function	91	ASATOP Clamping unit for close-fit liner DN 200 - DN 500 (ASA TL) and transition saddle (ASA TL KG)	107
FRIATOOLS fusion units - accessories	92	RPS Repair set	107
MINISCAN Mini-scanner	92	CLAMP 63 Alignment clamp d 20 - d 63	108
FWLESST Reader wand	92	CLAMP 180 Alignment clamp d 63 - d 180	108
2DSCAN 1D/2D scanner	92	SQM Manual squeezing-off tool for d 20 - d 125 pipes	108
MEMSTICK Memory stick	92	SQH Hydraulic squeeze-off tool for pipes d 63 - d 180	108
FRIATRACE FRIATRACE database software	93	RRC Re-rounding clamp for reinstating round cross section of squeezed-off pipes d 63 - d 180	109
PA USB FRIAMAT Parallel USB Adapter	93	FWXR Manual round clamp for pipes d 63 - d 250	109
SUPER P Supervisor Pass	93	FWXRH Hydraulic round clamp for pipes d 280 - d 900	109
SPASS Fusion-Pass	94	FWXRB Manual rounding clamp for pipes d 800 - d 1200	110
FPASS Remote start pass	94	PCUT Pipe cutter for pipes d 20 - d 140	110
ALTK FMT Transport boxes	94	PCUT S Pipe shears for pipes d 20 - d 63	110
CONTACT4 Socket contacts 4.0 mm	94	FWPM FRIALEN/FRIAFIT marker (silver)	110
ADFL Adaptor for flat contacts	95	FWSS Activating key for tapping tees	111
ADBK Adaptor for socket contacts 4.7 mm	95	FWSR T Ratchet for activating key for tapping tees DAA RED SNAP111	111
FRIATOOLS Scraper tools	96	FWSR Actuating key for parallel dome tapping tees (DAP)	111
FRIATOOLS scraper tools	97	FWDPA Pressure test adapter for DAA Classic, DAP, DAA TL, DAA TL RE	112
FWSG RA Compact scraper tool for pipe ends and outlet spigots d 25 - d 63	97	FWDPA Pressure test adapter for DAA RED SNAP	112
FWSG 63 Scraper tool for pipes d 20 – d 63 (1/2" - 2" IPS)	97	FWDPA SA Pressure test adapter	112
FWSG 225 Scraper tool for pipes d 75 – d 225 (3" - 8" IPS)	97	FRIATOOLS rental equipment service	112
FWSG 400 Scraper tool for pipe d 75 - d 400 (3" - 14" IPS)	97	FRIACLAMP stainless steel repair clamp	113
FWSG 710 L Scraper tool for pipes d 250 – d 710 (10" - 28" IPS)	98	FCE FRIACLAMP stainless steel repair clamp, one-piece	114
FWSG 710 S Scraper tool for pipes d 250 – d 710 (10" - 28" IPS) and spigot fittings	98	FCZ FRIACLAMP stainless steel repair clamp, two-piece	117
FWSG 900 L Scraper tool for pipes d 630 - d 900 (25" - 36" IPS)	98		
FWSG XL Large scraper tool for pipes d 800 to d 1200	98		
FWSG SE Compact scraper tool for pipe ends and saddle surfaces d 63 - d 315	99		
FWSG SE IPS Scraper tool for pipe ends and saddle surfaces 2 IPS - 12 IPS	99		
FWSK Scraper chain for pipe ends and saddle surfaces d 250 - d 1000	99		

2022 product range amendments at a glance

FRIALEN safety fittings

MR. SDR. 11 Reducer, SDR 11

Status	d ₁	d ₂	Order No.	Page
Not applicable	50	20	612069	22

FRIASTOP M Gas-Stop SENTRI GS by Maxitrol

Status	d	Order No.	Page
Not applicable	40	616194	40
	50	616196	
	63	616198	

DAV Tapping valve RED SNAP, SDR 11

Status	d ₁	d ₂	Order No.	Available from	Replaced Order No.	Page
	50	32	617024	Q2 / 2022	615955	
	63	32	617025	Q2 / 2022	615341	
	63	40	617026	Q2 / 2022	615342	
	63	63	616952	Q2 / 2022		
	75	32	617027	Q2 / 2022	615956	
	90	32	616960	Q1 / 2022	615344	
	90	40	616961	Q1 / 2022	615617	
	90	50	616962	Q1 / 2022	615346	
	90	63	616963	Q1 / 2022	615347	
	110	32	616964	Immediately	615348	
	110	40	616965	Immediately	615621	
	110	50	616966	Immediately	615350	
	110	63	616967	Immediately	615351	
	125	32	616968	Q1 / 2022	615352	
	125	40	616969	Q1 / 2022	615625	
	125	50	616970	Q1 / 2022	615354	
NEW	125	63	616971	Q1 / 2022	615355	
	140	32	616972	Q1 / 2022		33
	140	63	616973	Q1 / 2022	615930	
	160	32	616974	Immediately	615356	
	160	40	616975	Immediately	615629	
	160	50	616976	Immediately	615358	
	160	63	616977	Immediately	615359	
	180	32	616978	Immediately	615361	
	180	40	616979	Immediately	615633	
	180	50	616980	Immediately	615363	
	180	63	616981	Immediately	615364	
	200	32	616982	Immediately	615366	
	200	63	616984	Immediately	615369	
	225	32	616985	Immediately	615374	
	225	40	616986	Immediately	615641	
	225	50	616987	Immediately	615376	
	225	63	616988	Immediately	615377	

DBS Installation kit for tapping valves

Status	RD in m	Order No.	Replaced Order No.	Page
Discontinued part	0.45-0.7	616998	615866	34

EBS Installation kit for pressure tapping valves

Status	RD in m	Order No.	Alternative Order No.
	0.45-0.7	615866	
	0.7-1.0	615867	616999
	0.9-1.3	615335	617000
Omitted	1.2-1.8	615325	617001
	1.8-2.7	616327	617002
	2.6-3.5	616328	617003

DAV Tapping valve Classic, SDR 11

Status	d ₁	d ₂	Order No.	Available up to	Alternative Order No.	Page
Discontinued part	50	32	615955	Q4 / 2022	617024	
Discontinued part	63	32	615341	Q4 / 2022	617025	
Discontinued part	63	40	615342	Q4 / 2022	617026	
Discontinued part	75	32	615956	Q4 / 2022	617027	
Discontinued part	90	32	615344	Q3 / 2022	616960	
Discontinued part	90	40	615617	Q3 / 2022	616961	
Discontinued part	90	50	615346	Q3 / 2022	616962	
Discontinued part	90	63	615347	Q3 / 2022	616963	
Omitted	110	32	615348		616964	
Omitted	110	40	615621		616965	
Omitted	110	50	615350		616966	
Omitted	110	63	615351		616967	
Discontinued part	125	32	615352	Q3 / 2022	616968	
Discontinued part	125	40	615625	Q3 / 2022	616969	
Discontinued part	125	50	615354	Q3 / 2022	616970	34
Discontinued part	125	63	615355	Q3 / 2022	616971	
Discontinued part	140	63	615930	Q3 / 2022	616973	
Omitted	160	32	615356		616974	
Omitted	160	40	615629		616975	
Omitted	160	50	615358		616976	
Omitted	160	63	615359		616977	
Omitted	180	32	615361		616978	
Omitted	180	40	615633		616979	
Omitted	180	50	615363		616980	
Omitted	180	63	615364		616981	
Omitted	200	32	615366		616982	
Omitted	200	50	615368			
Omitted	200	63	615369		616984	
Omitted	225	32	615374		616985	
Omitted	225	40	615641		616986	
Omitted	225	50	615376		616987	
Omitted	225	63	615377		616988	



2022 product range amendments at a glance

VAM P Valve Tapping Saddles for irrigation systems, female thread for adaption to PVC-U fittings

Status	d	Thread	Order No.
	63	ACME 1"	616544
Omitted	63	ACME 1 1/4"	616543
	63	ACME 1 1/2"	616551

FRIAFIT sewage system

RES Reducers off-center (spigot fittings)

Status	d ₁	d ₂	Order No.	Page
NEW	225	200	681804	85

FRIATOOLS device technology

FRIAMAT prime eco Universal fusion unit with documentation function and traceability function as well as Bluetooth

Status	Version	Order No.	Page
NEW	With 1D/2D scanner	614124	90

FRIAMAT basic eco Universal fusion unit without documentation function

Status	Version	Order No.	Page
NEW	With 1D/2D scanner	614120	91

FRIAMAT print eco Universal fusion unit with simple documentation function

Status	Version	Order No.
Only as a loan device	With mini scanner	611122
	With reader wand	613122
	With 1D/2D scanner	614122

FWDPA Pressure test adapter for DAA RED SNAP

Status	Item reference	Order No.	Page
NEW	FWDPA for FRIALEN DAA RED SNAP	613597	112



Important information regarding fittings for safe connections in pipe construction with Aliaxis Deutschland

Stocked status

Please note during your planning and scheduling

- Items with an stocked status of 1 (MTS) are usually available from stock.
- Items with an stocked status 3 (MTO) are manufactured to order. Delivery time on request. These articles are excluded from return and exchange.

Packaging units and pallet units

The product catalogue show packaging units (BX) and pallet units (PU). Ordering in complete packages/pallets simplifies the process of receiving your goods and your storage. In addition, it promotes fast commissioning and therefore delivery by us. Product range clearly indicates that we have chosen reasonable and fair units for you.

Returns

The total value of the accepted return / item must be at least € 100.

Returned goods for credit must be approved by us in advance. Please register your return request with us. After successful verification, we will send you a return receipt with a unique number. Processing is not possible without this number. In the context of our quality management, the goods must also fulfil certain criteria. If necessary, we will be pleased to inform you about this separately. If the goods fulfil the criteria and the return is approved, then a credit note will be issued with a deduction of 30% for testing costs.

Inspection test certificates

For inspection test certificates according to DIN EN 10 204 - 3.1 we charge a fee of € 20.00 per order item. You can also order an inspection test certificates when placing an order.

In order to avoid unnecessary handling, we can also provide the certificate for FRIALEN articles. This requires only the specification of the component traceability batch, which you will find on the barcode label or in the delivery documents.

Product range

This product catalogue is available in the download area www.aliaxis.de/en

Quality

FRIALEN safety fittings, FRIALEN large pipe technology, the FRIAFIT sewage system and our FRIATOOLS Technical Equipment are subjected to ongoing quality controls with strict testing regulations, which are part of our comprehensive, according to DIN EN ISO 9001: 2015 certified quality management system.

FRIALEN safety fittings, FRIALEN large pipe technology, the FRIAFIT sewage system and our FRIATOOLS technical equipment are fully coordinated. All amendments, alterations and additions which occur in the course of technical development are taken into account accordingly. Our ongoing quality controls cover the FRIALEN safety fittings, the FRIALEN large pipe technology, the FRIAFIT sewage system, our FRIATOOLS technical equipment and the quality of the fused joints as a result of the interaction of these components. The operation and functional safety of devices from other manufacturers (external devices) are not subjected to our specifications and controls. Please follow our assembly instructions and the respective device operating instructions when laying the system.

Certifications of our management systems

In addition to the certification of the quality management system according to ISO 9001-2015, Aliaxis Deutschland GmbH has also received the certifications for the energy management system according to ISO 50001:2011 and the environmental management system according to DIN EN ISO 14001:2015. In this way, we underline our aspirations for sustainable development, production and use of our products.

You can find current certificates in the download area on our homepage.

Processing instructions and additional information

The processing takes place according to our assembly instructions, which are also available for download on the Internet at www.aliaxis.de. You can also find further information about the products and their processing, approvals, publications as well as seminar dates and contact persons via the navigation.

Technical details

The technical details in this product range are not complete. Detailed information can be found in our data sheets, which are available in the download area of the product programmes. Technical information regarding processing or use can be enclosed with the product and must be observed.

Brand name

For ease of reading, this product range does not include the marking by ® and ™. The following trademarks are registered: FRIALEN®, RED SNAP®, FRIAFIT®, FRIALOC®, FRIATOOLS®, FRIAMAT®, Sentry GS®, BAIO® as well as Gas-Stop™.

Date of printing/technical progress

All details correspond to the current state at the time of printing. We reserve the right to make amendments which are intended for technical progress. We assume no liability for printing errors.



Important information regarding fittings for safe connections in pipe construction with Aliaxis Deutschland

List of abbreviations

Abbreviation	Explanation
ABS	Acrylonitrile-Butadiene-Styrene
Art. No.	Article Number
CR	Chlorobutadiene rubber
de	Pipe outside diameter
DIBt	German Institute of Building Technology
DIN	German Institute for Standardisation
DN	Nominal outside diameter
DN/OD	Nominal diameter relative to outside diameter
DVGW	Deutsche Vereinigung für Wasserwirtschaft, Abwasser und Abfall e.V.
DVS	Deutscher Verband für Schweißen und verwandte Verfahren (German Association for Fusion and Related Processes)
e	Wall thickness
EN	European standards
EPDM	Ethylene-propylene rubber
FKM	Fluororubber
GFK	Glass fibre reinforced plastic
HM	Electrofusion welding units
HS	Butt-fusion of heating elements
LS	Stocked status
MTO	Made to Order
MTS	Made to Stock
NBR	Nitrile butadiene rubber
Order No.	Order Number
PA	Polyamide
PE	Polyethylene
PU	Pallet unit
POM	Polyoxymethylene
PP-B	Polypropylene block copolymer
PP-H	Polypropylene homopolymer
PP-R	Polypropylene random copolymer
PTFE	Polytetrafluorethylene
BX	Sales Unit
PVC-C	Polyvinyl chloride, post-chlorinated
PVC-U	Polyvinyl chloride, plasticizer-free
PVDF	Polyvinylidene fluoride
RD	Pipe cover
RG	Discount group
RQ	On request
SBR	Styrene-butadiene rubber
SDR	Standard Dimension Ratio (diameter-wall thickness ratio)
SW or WS	Wrench size
Z99, ZZ#	Discount on request



Delivery and payment terms of Aliaxis Deutschland

1. Scope

- 1.1 All deliveries and services are subject to our delivery and payment terms as follows. Other conditions do not form part of the contract, even when we do not object to them explicitly.
- 1.2 Our delivery terms apply to those persons only who act in their commercial or independent professional capacity on conclusion of the contract (contractors as defined under § 310, Para. 1 of the German civil code BGB), to public law entities, and to separate public estates.
- 1.3 All services are subject to our separate terms and conditions for customer, maintenance, and repair services.
- 1.4 All hiring services are subject to our separate general terms and conditions for the hire of fusion, scraper, and accessory equipment.

2. Conclusion of contract

- 2.1 Our offers are nonbinding and subject to change provided that they have not been marked explicitly as binding or contain a specific acceptance period.
- 2.2 Verification of the contents and scope of a contract requires our order confirmation issued in writing.
- 2.3 Custom makes and prefabricated piping elements are designed and manufactured according to the technical documentation, drawings, and other details submitted by the ordering party. If, at the ordering party's request, design and manufacturing documents of this kind are drawn up by us or our technical personnel, these are submitted for approval to the ordering party before start of production. Acceptance is deemed as having been made when the ordering party fails to accept the contracted work within a period set by us of seven days following receipt of the design and manufacturing documents and when we have referred the ordering party at the commencement of this period to the foreseeable consequences of this failure. We accept changes to the completed custom makes and prefabricated piping elements only when the ordering party has declared explicitly and in writing its willingness to assume the additional costs involved. This does not affect the rights of the ordering party on the grounds of services not provided in accordance with the contract.
- 2.4 The design and manufacturing documents, the images, the cost estimates, the drawings, the calculations, the files, and all other material, details, and information we provide must be treated confidentially. Their ownership and copyrights remain our property. Without our prior consent, they may not be used for any purpose other than those agreed. Their communication or access to third parties requires our explicit consent.
- 2.5 The technical content of the ordered goods may be changed provided that this does not induce a fundamental change in their functionality, or unless the ordering party verifies unacceptability.
- 2.6 We accept warranties for the durability and/or consistency of the ordered goods and/or the goods we manufacture at the ordering party's request only when these warranties have been confirmed explicitly in our order confirmation or our advertisements.

3. Delivery

- 3.1 Delivery dates and periods can be observed only when we ourselves are supplied in due order and when the ordering party fulfils duly its obligations. If these obligations are not fulfilled duly or the ordering party wishes subsequent changes, the delivery periods are extended appropriately.
- 3.2 The delivery period commences on the date of our order confirmation issued in writing. It is deemed fulfilled when on its expiry the goods have left the works or their readiness for shipping has been declared.
- 3.3 The delivery period is also extended appropriately when their nonobservance can be put down to force majeure or to any other events unforeseeable at the conclusion of contract and outside of our responsibility, including disruption to production of any nature; difficulties in material and energy acquisition; transport delays; industrial action; legitimate lockouts; shortage of labour, power, or raw materials; difficulties in the acquisition of requisite licences; deliveries not duly provided by suppliers, etc.
- 3.4 If the ordering party defaults on acceptance and violates culpably other obligations to cooperate, we are entitled to demand recompense for any damage incurred, including any additional expenditure. We also have the right to exact claims beyond this.

4. Prices, payment terms, and shipping

- 4.1 Our prices are for shipping ex works or ex stores, not including the statutory value added tax. The costs for insurance, packaging, shipping, and custom duties are invoiced separately to the ordering party, provided that we have not agreed explicitly otherwise in our price list valid at the time.
- 4.2 If not agreed otherwise in writing, our invoices are payable immediately on receipt without deductions. The statutory rules apply in the event of default.

- 4.3 We reserve the right to change our prices accordingly when, following conclusion of contract, costs rise or fall, specifically as a result of collective bargaining agreements or changes in the prices of materials. Verification of such we submit to the ordering party on demand. If a new price list comes into force during contracts with an agreed life exceeding four months between conclusion and delivery, we are entitled to invoice the prices valid on the day of delivery.
- 4.4 If partial deliveries have been agreed or are acceptable to the ordering party, we are entitled to issue a separate invoice for each and every partial delivery, which must be paid in accordance with the above conditions.
- 4.5 On the ordering party's failure to fulfil the payment terms or under circumstances casting doubt on the ordering party's creditworthiness, we are entitled to demand immediate payment for all services. In this event, all discount agreements, discounts, price reductions, etc., are deemed void. In addition, we are entitled to retain all pending deliveries, to ship them only against advance payment or security, to withdraw from the contract, and to demand compensation. We are further entitled to prohibit the further sale of goods delivered under our rights of ownership and to retrieve immediately the goods at the ordering party's expense once we have withdrawn from the contract.
- 4.6 Containers, wire mesh pallets, EUR-pallets, support rings, and similar remain our property if not agreed otherwise. The named objects must be returned carriage free and in faultfree condition to the place of performance within one month of receipt. Otherwise we are entitled to invoice the ordering party for the replacement.

5. Transfer of risk, final acceptance

- 5.1 The risk is transferred to the ordering party when the delivery is ready to ship and this has been declared, or on final acceptance. This applies also when shipping or acceptance is delayed under circumstances outside of our responsibility. If readiness for shipping is not declared, the risk is transferred to the ordering party when the goods are passed to the carrier, but no later than the date the goods leave the works or stores. This also applies when our own means of transport are used and for carriage paid deliveries.
- 5.2 If final acceptance has been agreed, this must be performed immediately by its set end date, preferably after the readiness for final inspection has been declared. The ordering party may not refuse final acceptance in the event of a nonessential deficiency.

6. Notice of defects, warranty claims, limitations

- 6.1 On receiving the delivered goods, the ordering party must inspect them immediately and carefully for deficiencies. The ordering party must submit notices of defects immediately, but no later than fourteen days, after receipt of the goods. The same period applies to concealed deficiencies, commencing on the date of their discovery. Deficiencies not reported in the due time are not approved.
- 6.2 Justified complaints are remedied with subsequent services or replacements, as we see fit. If we fail to remedy the deficiency within an appropriate period or after two attempts at the most, or if we deliver a replacement, the ordering party has the right to withdraw from the contract or to demand a reduction in the purchase price. Withdrawal is excluded when our violation of an obligation is minor only.
- 6.3 The limitation for warranty claims is:
 - a) five years on delivered construction materials that have been installed and have caused the defectiveness of a structure;
 - b) one year on other, new goods delivered to contractors;
 - c) two years in all other cases.
 - d) Liability for defects is excluded for used goods delivered to contractors.
 - e) The periods under b) and d) do not apply to the ordering party's damage compensation claims on the grounds of risks to life, body, or health or of wilful or grossly negligent violations to obligations by us, our legal representatives, or our vicarious agents. These claims expire by limitation under the law. If we are not charged with wilful violation of the contract, our liability for damage compensation is limited to the foreseeable, typical extent.
 - f) This does not affect any further special laws on limitations (specifically § 438 Para. 1 No. 1, Para. 3, §§ 444, 445 b BGB).
- 6.4 The limitation for warranty claims commences on the day the object is shipped or, if this is necessary, subjected to the final acceptance.
- 6.5 In the case of delivered replacements and remedies, the limitation does not commence afresh for the replaced or remedied goods, including goodwill cases. If, in exceptional cases, there is acknowledgement, this applies to those deficiencies only that formed part of the wish for repeat performance.
- 6.6 Warranty claims are ruled out in particular for deficiencies that are incurred after the transfer of risk as a result of unsuitable or improper use, incorrect installation, or incorrect maintenance by the ordering or third parties,



Delivery and payment terms of Aliaxis Deutschland

improper operation, natural wear and tear, improper care, unsuitable resources, defective construction work, unsuitable building ground, or particular external effects that are unforeseen after conclusion of contract.

7. Reservation of ownership

- 7.1 All of our deliveries are effected under ownership rights. The goods remain our property until payment has been defrayed in full of all accounts receivable from the business relationship with the ordering party. In the case of a current account, the reserved ownership is deemed security for our outstanding receivables.
- 7.2 The ordering party is entitled to resell the delivered goods as part of its ordinary course of business. It may not, however, either pledge or assign as security the reserved goods.
- 7.3 When reselling, the ordering party cedes immediately to us all accounts receivable and all subsidiary rights engendered to it by the resale. This applies irrespectively of whether the ordering party sells the reserved goods unprocessed, worked, processed, or together with other objects. If the resale includes goods not belonging to us, the assignment is deemed the value of the reserved goods only. The value measured is based on our sales prices.
- 7.4 Reserved goods are always worked and processed for our benefit as the manufacturer as defined under § 950 BGB, but without obliging us. The processed goods are deemed reserved goods as defined under these terms. If reserved goods are processed or mixed inseparably with other objects not belonging to us, we acquire coownership of the new object in the ratio of the reserved goods' invoiced value to the invoiced value of the other used goods at the time of processing or mixing. The arising coownership rights are deemed reserved goods as defined under these terms. The ordering party is obliged on demand to refer the purchaser of the reserved goods to our ownership rights.
- 7.5 The ordering party is authorised to collect the account receivable from the resale, without detriment to our own collection authority. As long as the ordering party fulfils duly its payment obligations, we do not claim the account receivable. On demand the ordering party must inform us of the debtors for the assigned accounts receivable and to report the assignment to them. This does not affect our right to inform ourselves third party debtors of the assignment. The ordering party is not permitted to assign third party accounts receivable to third parties or to agree on nonassignability with the third party debtor.
- 7.6 The ordering party is obliged to inform us immediately and by the fastest means of a pledge or any other detriment to our security right by third parties. The ordering party is obliged to hand over to us all of the documentation needed to protect our rights and to reimburse to us the costs incurred by a requisite intervention.
- 7.7 We are obliged, as we see fit, to release securities to 10% in excess of the accounts payable in need of security.
- 7.8 In the event of the ordering party's violation of contract, in particular default of payment, we are entitled to withdraw from the contract and to retrieve the objects delivered under reserved ownership. Also, the ordering party is obliged to return them.
- 7.9 The ordering party is obliged to insure the goods to an adequate extent for the duration of our reserved ownership.

8. Force majeure – right to withdraw

When force majeure or other circumstances we cannot influence hinder us in the fulfilment of our delivery obligations, or when such reasons render this fulfilment unacceptable, we are entitled to withdraw from the contract. The ordering party is not entitled to compensation claims in this event. The right to withdraw may also be observed when the ordering party is first informed of an extension to the delivery period.

9. Liability for compensation of culpable damage

- 9.1 Our liability for damage compensation, irrespectively of the legal grounds, in particular from impossibility, delay, defective or incorrect delivery, violation of contract, breach of obligations during contract negotiations, and unpermitted activities, if caused by culpability in each and every case, is limited to the extent under 9.
- 9.2 We are liable to compensate for damages, irrespectively of the legal grounds, in the event of wilful culpability and gross negligence.
- 9.3 On condition of a smaller scope of liability, we are liable for slight negligence under the law (e.g. for due care in our own matters) only
- for damages as a result of harm to life, the body, or health and
 - for damages resulting from the not inconsiderable violation of an essential contractual obligation (an obligation whose fulfilment first makes at all possible the ordinary performance of the contract and on whose fulfilment the contracting partner relies or may rely regularly). In this case, however, our liability is restricted to the compensation for the predictable, typical damage.

9.4 The liability limitations under 9.3 also apply in the event of violations of obligations by or for the benefit of persons whose culpability lies within our responsibility under the law.

9.5 The limitations of and exemptions from liability under 9.3 do not apply when we fail deliberately to communicate a deficiency, when we have granted a warranty on the consistency of the object, or there are claims under the product liability laws.

9.6 The ordering party may only withdraw or terminate when we are responsible for violating an obligation not consisting in a deficiency. The ordering party has no free right to terminate (in particular as set down under §§ 651, 649 BGB). In all other cases, the legal prerequisites and consequences apply.

10. Data protection

We store the ordering party's data that may contain personal details for handling the contractual relationship – Art 6, Para. 1(1b) GDPR. When required for the fulfilment of the contract, we communicate these data to third parties (e.g. insurance houses). Further details on how we handle personal data can be viewed on our website.

11. Non assignability

If this is not agreed specifically otherwise with the ordering party, the ordering party is not entitled without our prior consent to transfer contractual rights to third parties.

12. Applicable laws, venue, place of performance

- 12.1 Exclusively German law applies, excluding the United Nations Convention on Contracts for the International Sale of Goods.
- 12.2 The sole venue for disputes between the contracted parties is Mannheim, when the ordering party is a merchant, a public law entity, or a separate public estate or does not have general jurisdiction in Germany. Notwithstanding, we reserve the right to take legal action against an ordering party that has no general jurisdiction in Germany also before other competent law courts, as we see fit.
- 12.3 The place of performance is our head office when this is not specified otherwise in the order confirmation.

Mannheim, December 2019

Aliaxis Deutschland GmbH
Steinzeugstr. 50
68229 Mannheim, Germany
Tel: +49 621 486-0
info.de@alixaxis.com
www.alixaxis.de



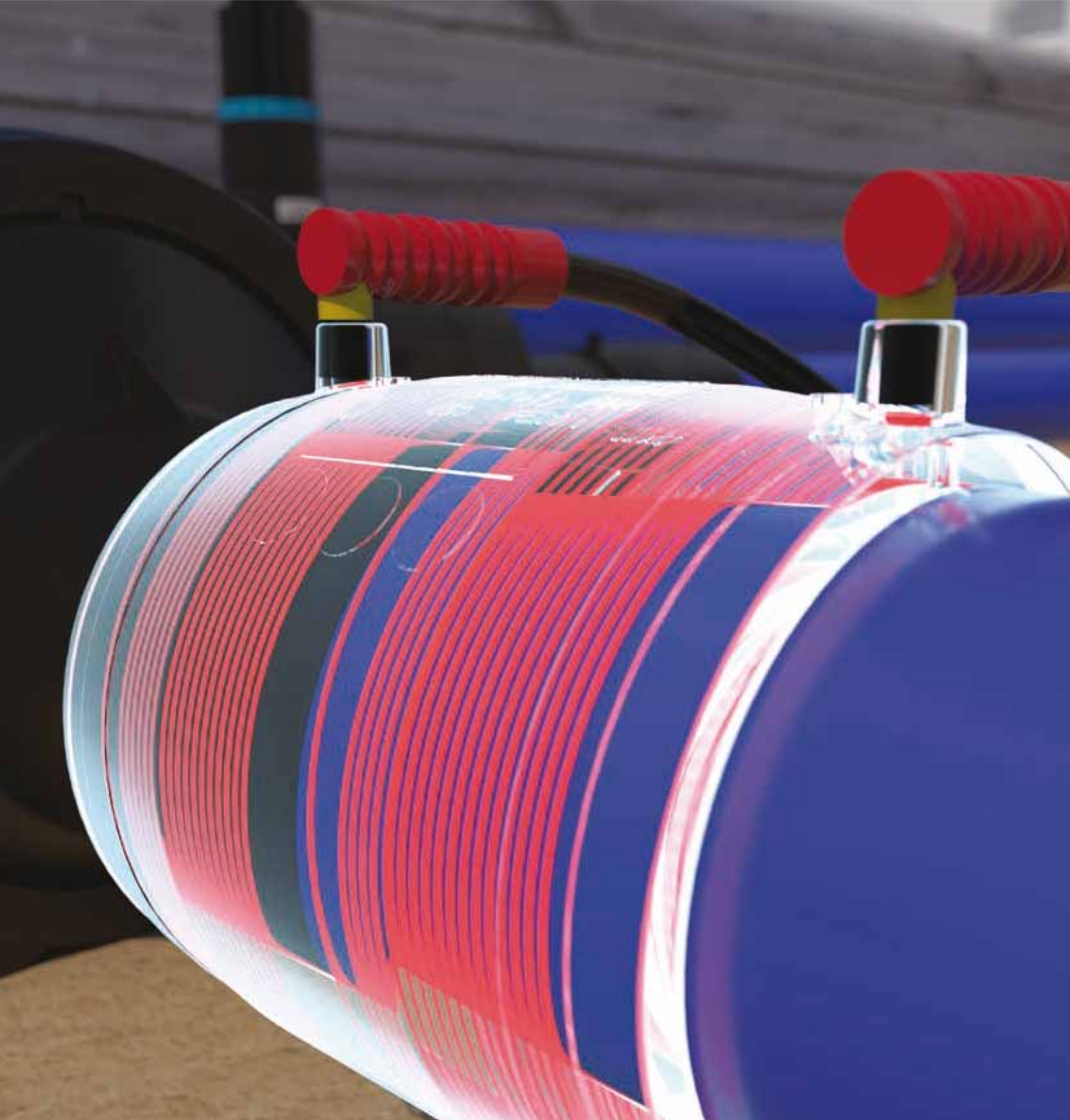

FRIALEN[®] safety fittings

For sustainable pipes for gas, water networks and industrial systems made of PE.

Product range ES 42/22

Things worth knowing about FRIALEN® safety fittings and this product range

Component traceability

Each component is equipped with an additional barcode for component traceability.

Product Certifications

FRIALEN safety fittings and FRIAFIT couplers AM including shut-off valves comply with the relevant standard requirements, e.g. for gas EN1555-3, -4, ISO 4437-3, -4 for drinking water and pressure drainage EN12201-3, -4 and ISO 4427-3. Specific fields of application are mentioned in the product description.

Worldwide certifications underline the highest quality level of FRIALEN and FRIAFIT safety fittings, including shut-off valves, which are marked with the following quality brands:

You can find current certificates in the download area on our homepage.

The scope of the respective certifications of individual products is based on applicability and market requirements. Please inspect for individual cases whether the required certification is available for the respective product.



H2 Test certificate

Our products are H2-ready-100! The scope of application of our FRIALEN shapes and fittings has been extended to include hydrogen [H2]. This means that our products can be used with the application of 100% hydrogen to MOP 10 bar. This is confirmed by test certificates of the DBI - Gastechnisches Institut GmbH.

Suitable components are marked with an H2 icon in the product range. Please contact our sales representatives for a planned assignment.



Fusability

FRIALEN safety fittings can be fused with pipes with SDR levels 17.6 (s minimum = 3 mm) up to 11. Deviations from these areas are mentioned in the product description. Other levels of SDR can be processed on request.

FRIAFIT couplers AM SDR17 can be fused with pipes SDR17 to SDR33.

FRIALEN saddle components / fittings ≤ d63 are only to be processed with pipes ≤ SDR11. From d 50, pressure tapping tees with quick-action clamping lever DAA can also be processed with pipes SDR 17.6 - SDR 11.

Please also note the details of the respective fusion-capable SDR levels, which are indicated on the bar code label of the fitting and further binding labels directly on the product.

Please contact our application technology if you want to process thin-walled pipes > SDR17,6.

FRIALEN safety fittings and FRIAFIT couplers AM can be processed with pipes made of PE-100 and PE-100 RC, PE-80, PE-63, PE-50 to DIN 8074/75, EN 1555, EN 12201, ISO 4437 and ISO 4427, PE-Xa on request, PE-LD to DIN 8072/73. For PE pipes, a melt flow rate MFR 190/5 in the range from 0.2 to 1.7 g/10 min. applies.

For components with MFR < 0.20, a confirmation of suitability is required. PE-LD pipes can be fused at ambient temperatures > 0 °C.

FRIALEN safety fittings and FRIAFIT couplers AM made of PE 100 fulfil the requirements of EN 1555, EN 12201, ISO 4427 and ISO 4437. The processing of the FRIALEN and FRIAFIT safety fittings is possible with FRIAMAT fusion units at ambient temperatures between - 10 °C and + 45 °C.

In addition to our assembly instructions, the material-specific or system-specific standards and assembly guidelines apply to material-transfer joints, e.g. screw or weld joints, particularly with regard to sealing, heat penetration during steel fusion and corrosion protection.

For case-by-case restrictions regarding laying and processing FRIALEN and FRIAFIT safety fittings in general, please read our assembly instructions, which you will find in the respective product programme in the download area. Our in-house customer service representatives will also be pleased to answer any questions.

Pressure bearing capacity

The pressure bearing capacity of FRIALEN safety fittings and FRIAFIT couplers AM made of PE 100 is determined by the SDR (standard dimension ratio) designation.

$SDR = \text{pipe outside } \varnothing d / \text{pipe wall thickness } s$

The current standards, as listed under chapter „Fusability“, are decisive for this. Taking into account the design factor C (calculation coefficient for components made of PE), the following pressure levels result:

Fitting material: PE 100 (FRIALEN standard)	Water	Gas
SDR Level	Maximum working pressure in bar at C = 1.25	Maximum working pressure in bar at C = 2
26	6	-
17	10	5
11	16	10
9	20	-
7,4	25	-



Things worth knowing about FRIALEN® safety fittings and this product range

Fusion process

FRIALEN and FRIAFIT safety fittings can be processed with universal fusion units, e.g. the FRIAMAT construction series. The fusion parameters are automatically transmitted by the fitting barcode.

FRIALEN safety fittings can also be processed by fusion units with a fixed output voltage of 39.5 V when the fusion time is entered manually. The fusion time is specified on the bar code for manual input of the fusion parameters.

ATTENTION! When utilising fixed voltage fusion units, the permissible processing range is at ambient temperatures from -5 °C to +35 °C. The fusion time specified on the fitting bar code applies to the entire temperature range.

ATTENTION! The 39.5 V fusion time and the bar code fusion time can be different!

Cooling time

FRIALEN safety fittings and FRIAFIT couplers / elbows / T-pieces / transition pieces:
The cooling times (CT) indicated on the bar code labels are understood to be the times until the movement of the welded connection.

Longer cooling times must be maintained until pressure is applied. Please read our assembly instructions.

FRIALEN and FRIAFIT drilling valves, valves and saddles, valves / clamps:
The cooling times (CT) indicated on the bar code labels are understood to be the times up to the drilling.

A pressure test of the saddle weld seam/outgoing pipe can be executed earlier. Please read our assembly instructions.

Processing instructions and additional information

The processing takes place according to our assembly instructions, which are also available for download on the Internet at www.aliaxis.de. You can also find further information about the products and their processing, approvals, publications as well as seminar dates and contact persons via the navigation.

FRIALEN saddle fittings top-loading

The dimension specification, including the values in brackets, indicates the permissible range for assembly and fusion for the saddle fitting. Where applicable, the standard scope of application is restricted due to technical restrictions (e.g. drill length/pipe wall thickness or bore diameter/diameter of the blocking bladder). The suitability must always be inspected with deviating application purposes.





Hydrogen

Future-perspective on hydrogen

By 2050, energy in Germany is to be mainly produced from renewable sources. Here in focus: CO₂ reduction. Markus Wilhelm, Director HUB Development Infrastructure EMEA: "Green energies will prevail, even for heating and DHW." The switch over to renewable energies such as hydrogen (H₂) is a decisive criteria for an efficient and environmentally friendly energy supply.

The substance of the energy future

The natural gas supply industry is working on alternatives to fossil fuels. The so-called "green hydrogen" is regarded as climate neutral and can be stored in large volumes. If hydrogen is produced by electrolysis, i.e. by splitting it with electricity from water (H₂O), then no harmful carbon (CO₂) is created. The remaining oxygen can then be released to the environment without concern.

Climate neutral generation and hydrogen combustion

When hydrogen burns with (air) acid it turns into energy and water and thereby determines the CO₂ footprint. The reaction with atmospheric nitrogen produces a very small amount of nitrogen oxide, although no hydrocarbons, sulphur oxides, carbon monoxide or carbon dioxide. Power-to-gas (P2G) stands for the conversion of electric current into gas or hydrogen. The generation of regenerative energy by sun or wind is executed discontinuously, as it always depends on weather and time of day or season. Generated amounts of current which exceed the acute demand can be converted into green hydrogen by P2G.

Demand for future-proof pipework

Adding 20 percent hydrogen to natural gas and/or switching over to a pure hydrogen supply is a technical chal-



FRIALEN in the hydrogen application

lenge. It comprises of the generation, transportation, storage, distribution and combustion of green hydrogen in the domestic gas boiler or gas-powered devices or appliances. Our task is to develop hydrogen-suitable pipeline structures with a service life of up to 100 years - i.e. future-orientated materials, components and connection techniques.

Aliaxis is ready for the future

Hydrogen will be a key fuel for our supply. Aliaxis is ready for this and has already received the H₂-ready-100 certificate of suitability for its FRIALEN product range: All components, which are marked with the H₂ symbol, are now



suitable for use with up to 100 percent hydrogen in terms of tightness and service life.

Safety Technology

Open wire design

Exposed heating coils during fusion process

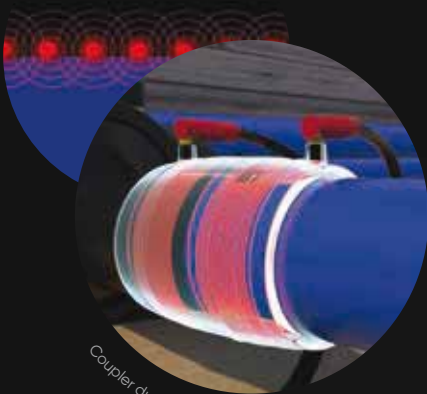

Coupler during fusion process

Optimum heat transfer



Immediate heat transfer within the contact area between the surfaces.



Energy-saving through effective energy utilisation.



Exposed heating coils made of corrosion-resistant wire.

Delivering the energy to where it is needed - for a **SUPERIOR FUSION RESULT.**



UB SDR 11

Coupler without inner stop, SDR 11

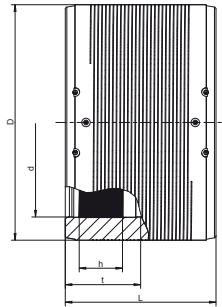

Coupler UB SDR 11 without inner stop

- Gas, water and H₂
- Maximum pressure: Gas 10 bar; Water 16 bar
- Material; PE 100
- Safety technology
- DVGW test mark: DV-8601AU2248, DV-8606AU2249, DV-8611AU2250 and DW-8610CN04200

Note:

From nominal size 400 with separate fusion zone and preheating technology.

PE 100 SDR 11

Maximum permissible working pressure 16 bar (water) / 10 bar (gas)



d	Order No.	SDR range	D	L	Weight [kg]	BX	PU	Stock status
16	616577	11	29	60	0.030	135	4.320	3
32	612662	11 - 17,6	45	77	0.064	60	1.920	1
40	612663	11 - 17,6	54	86	0.096	40	1.280	1
50	612664	11 - 17,6	68	98	0.151	25	800	1
63	612665	11 - 17,6	82	112	0.225	15	480	1
75	612666	11 - 17,6	98	122	0.360	50	400	1
90	612667	11 - 17,6	114	157	0.510	30	240	1
110	612668	11 - 17,6	137	159	0.705	24	192	1
125	612669	11 - 17,6	156	172	0.946	16	128	1
140	615001	11 - 17,6	174	184	1.270	12	96	1
160	612671	11 - 17,6	199	190	1.772	8	64	1
180	612672	11 - 17,6	220	210	2.088	6	48	1
200	612673	11 - 17,6	247	220	2.798	1	56	1
225	612674	11 - 17,6	277	236	3.950	1	36	1
250	612675	11 - 17,6	315	246	5.800	1	24	1
280	615073	11 - 17,6	347	285	7.740	1	18	1
315	612670	11 - 17,6	390	300	10.040	1	18	1
355	615074	11 - 17,6	445	300	14.600	1	9	1
400	615075	11 - 17,6	500	320	20.800	1	4	1
450	615076	11 - 17,6	560	340	30.000	1	4	1
500	615124	11 - 17,6	630	360	40.000	1	2	1
560	616312	11 - 17,6	715	380	55.000	1	2	1
630	616269	11 - 17,6	810	420	79.600	1	2	1
710	616313	11 - 17,6	900	442	101.000	1	1	1
800	616314	11 - 17,6	1000	500	138.800	1	1	1
900	616440	11 - 17,6	1130	600	210.300	1	1	3
1000	616989	11	1200	680	223.600	1	1	3



FRIALEN couplers

MB SDR 11

Coupler with easily removable inner stop, SDR 11

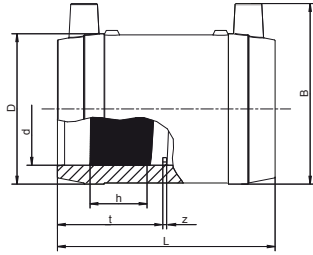

Coupler MB SDR 11 with inner stop

- Gas, water and H₂
- Maximum pressure: Gas 10 bar; Water 16 bar
- Material; PE 100
- Easily removable inner stop
- Safety technology
- DVGW test mark: DV-8601AU2248 and DV-8606AU2249

PE 100 SDR 11

Maximum permissible working pressure 16 bar (water) / 10 bar (gas)



d	Order No.	SDR range	D	L	Weight [kg]	BX	PU	Stock status
20	612680	11	33	60	0.040	110	3520	1
25	612681	11	38	66	0.047	90	2880	1
32	612682	11 - 17,6	45	78	0.064	60	1920	1
40	612683	11 - 17,6	54	86	0.100	40	1280	1
50	612684	11 - 17,6	68	98	0.150	25	800	1
63	612685	11 - 17,6	82	110	0.221	15	480	1
75	612686	11 - 17,6	98	122	0.360	50	400	1
90	612687	11 - 17,6	114	157	0.510	30	240	1
110	612688	11 - 17,6	137	159	0.710	24	192	1
125	612689	11 - 17,6	156	172	0.950	16	128	1
140	612690	11 - 17,6	174	184	1.270	12	96	1
160	612691	11 - 17,6	199	190	1.770	8	64	1

FRIALONG SDR 11 Long coupler with easily removable inner stop, SDR 11

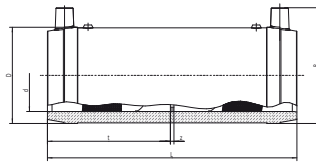

Long coupler FRIALONG SDR 11 with inner stop

- Gas, water and H₂
- Maximum pressure: Gas 10 bar; Water 16 bar
- Material; PE 100
- Easily removable inner stop
- Optimum pipe routing
- Tension-free fusing
- Safety technology
- DVGW test mark: DV-8601AU2248

PE 100 SDR 11

Maximum permissible working pressure 16 bar (water) / 10 bar (gas)



d	Order No.	SDR range	D	L	Weight [kg]	BX	PU	Stock status
32	615736	11 - 17,6	45	136	0.110	40	1280	1
40	615737	11 - 17,6	54	146	0.140	30	960	1
50	615608	11 - 17,6	68	175	0.250	16	512	1
63	615738	11 - 17,6	82	197	0.370	10	320	1



FRIALEN couplers

UB SDR 17

Coupler without inner stop, SDR 17

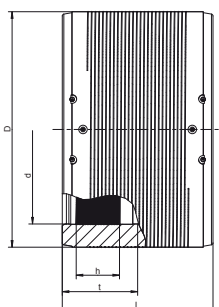

Coupler UB SDR 17 without inner stop

- Gas and water
- Maximum pressure: Gas 5 bar; Water 10 bar
- Material; PE 100
- Safety technology
- Separate fusion zone
- DVGW test mark: DV-8611AU2250 and DW-8610CN0420

Note

From nominal size 560 with preheating technology and from nominal size 1000, only one FRIAMAT XL is to be utilised, which is available as a loan device under Order No. 613091.

PE 100 SDR 17

Maximum pressure: Water 10 bar / gas 5 bar



d	Order No.	SDR range	D	L	Weight [kg]	BX	PU	Stock status
315	616529	17 - 26	356	280	5.880	1	18	1
355	616530	17 - 26	400	290	7.600	1	18	1
400	616531	17 - 26	450	300	10.100	1	9	1
450	616532	17 - 26	506	320	13.650	1	4	1
500	616533	17 - 26	562	350	18.250	1	4	1
560	615706	17-17,6	630	380	24.190	1	2	1
630	615726	17-17,6	710	420	34.870	1	2	1
710	615994	17-33	800	442	46.000	1	2	1
800	616290	17-33	900	500	65.900	1	1	1
900	616345	17	1024	500	91.500	1	1	1
1000	616403	17	1130	610	128.000	1	1	3
1200	616416	17	1356	670	205.000	1	1	3

UB SDR 9

Coupler without inner stop, SDR 9

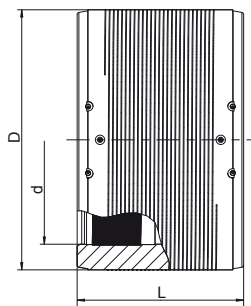

Coupler UB SDR 9 without inner stop

- Water
- Maximum pressure: 20 bar
- Material; PE 100
- Safety technology
- Separate fusion zone
- DVGW test mark: DV-8611AU2250

Note:

From nominal size 400 with preheating technology.

PE 100 SDR 9

Maximum permissible working pressure 20 bar (water)



d	Order No.	SDR range	D	L	Weight [kg]	BX	PU	Stock status
400	616441	9 - 11	500	320	20.800	1	4	1
450	616447	9 - 11	560	340	30.000		4	3
500	616445	9 - 11	630	360	40.000		2	3
560	616446	9 - 11	715	380	55.000		2	3
630	616439	9 - 11	810	420	79.600		2	3

The minimum purchase quantity is one pallet unit (PU).



FRIALEN couplers

UB SDR 7,4

Coupler without inner stop, SDR 7.4

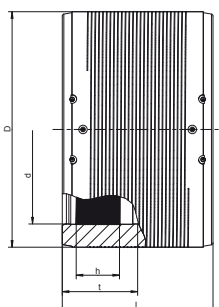

Coupler UB SDR 7.4 without inner stop

- Water
- Maximum pressure: 25 bar
- Material; PE 100
- Safety technology
- Separate fusion zone from d 280
- DVGW test mark: DV-8606AU2249 and DV-8611AU2250

Note:

From nominal size 280 with preheating technology (optional).



PE 100 SDR 7.4

Maximum permissible working pressure 25 bar (water)

d	Order No.	SDR range	D	L	Weight [kg]	BX	PU	Stock status
90	616270	7,4 - 11	117	138	0.530	30	240	1
110	616271	7,4 - 11	142	159	0.870	24	192	1
125	616272	7,4 - 11	160	172	1.230	16	128	1
140	616273	7,4 - 11	181	184	1.640	12	96	1
160	616274	7,4 - 11	206	203	2.360	8	64	1
180	616282	7,4 - 11	225	210	2.700	6	48	1
200	616283	7,4 - 11	250	224	3.610	2	36	1
225	616284	7,4 - 11	280	240	4.900	1	33	1
250	616285	7,4 - 11	315	246	6.700	1	24	1
280	616286	7,4 - 11	355	268	9.300	1	18	3
315	616287	7,4 - 11	400	285	12.100	1	18	1
355	616288	7,4 - 11	450	300	16.700	1	9	1

KM SDR 17

Conical ring coupler, SDR 17

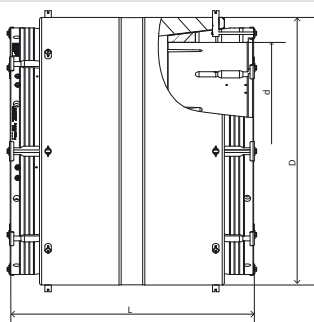

Conical ring coupler KM SDR 17

- Gas and water
- Maximum pressure: Gas 5 bar; Water 10 bar
- Material; PE 100
- Combination of coupler and clamping coupler
- Problem solver (pipe ovally and different diameters)
- Safety technology
- Separate fusion zone

Note:

Only one FRIAMAT XL is to be utilised, which is available as a loan device under the Order No. 613091.



PE 100 SDR 17

Maximum permissible working pressure 10 bar (water) / 5 bar (gas)

d	Order No.	SDR range	D	L	Weight [kg]	BX	PU	Stock status
355	616535	17 - 26	497	705	36.500	1	1	3
400	616536	17 - 26	550	730	46.000	1	1	3
450	616537	17 - 26	602	750	54.000	1	1	3
560	616539	17 - 26	730	850	88.100	1	1	3
630	616523	17 - 26	805	940	135.000	1	1	3
800	616541	17 - 26	1005	1065	207.000	1	1	3
1000	616434	17 - 26	1245	1145	350.000	1	1	3
1200	616435	17 - 26	1450	1290	500.000	1	1	3



FRIALEN couplers

MR SDR 11 Reducer, SDR 11

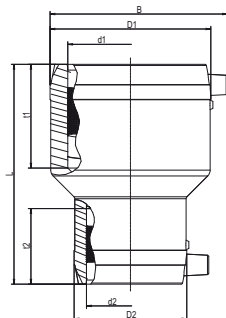

Reducer MR, SDR 11

- Gas, water and H₂
- Maximum pressure: Gas 10 bar; Water 16 bar
- Material; PE 100
- Safety technology
- DVGW test mark: DV-8601AU2248 and DV-8606AU2249

PE 100 SDR 11

Maximum permissible working pressure 16 bar (water) / 10 bar (gas)



d ₁	d ₂	Order No.	SDR range	D ₁ /D ₂	L	Weight [kg]	BX	PU	Stock status
20	16	616824	11 - 17,6	32/28	75	0.035	70	2240	1
32	16	616452	11 - 17,6	45/28	91	0.060	80	2560	1
32	20	615386	11 - 17,6	45/32	88	0.060	80	2560	1
32	25	615502	11 - 17,6	45/38	88	0.070	70	2240	1
40	20	615387	11 - 17,6	54/32	98	0.080	60	1920	1
40	25	616751	11 - 17,6	54/38	101	0.090	120	1280	1
40	32	615388	11 - 17,6	54/45	98	0.090	50	1600	1
50	25	616752	11 - 17,6	66/38	107	0.120	130	960	1
50	32	612070	11 - 17,6	68/45	110	0.140	32	1024	1
50	40	612071	11 - 17,6	68/54	110	0.140	25	800	1
63	32	615389	11 - 17,6	82/45	125	0.210	18	576	1
63	40	615390	11 - 17,6	82/54	125	0.220	16	512	1
63	50	612072	11 - 17,6	82/68	125	0.230	16	512	1
75	63	616583	11 - 17,6	94/79	143	0.325	15	270	1
90	50	615391	11 - 17,6	117/68	160	0.470	15	270	1
90	63	615392	11 - 17,6	117/82	160	0.510	15	270	1
90	75	616582	11 - 17,6	113/94	159	0.505	15	270	1
110	63	615393	11 - 17,6	142/82	160	0.730	10	180	1
110	90	615693	11 - 17,6	140/115	180	0.900	8	144	1
125	90	615694	11 - 17,6	155/115	200	0.980	8	144	1
125	110	616510	11 - 17,6	157/137	202	1.300	16	128	1
160	110	615695	11 - 17,6	201/140	230	1.990	8	64	1
180	125	616511	11 - 17,6	214/155	275	2.600	1	60	1
225	160	616356	11 - 17,6	282/203	270	4.860	1	36	1

REM SDR 17 Reducer, SDR 17 for Relining

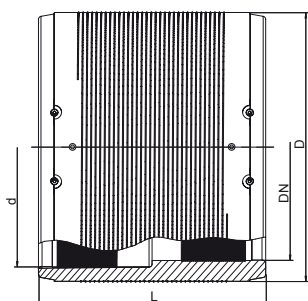

Reducer REM, SDR 17 for Relining

- Gas and water
- Maximum pressure: Gas 5 bar; Water 10 bar
- Material; PE 100
- Problem solver for pipe refurbishment work (relining)
- Safety technology
- Separate fusion zone
- Preheating technology

PE 100 SDR 17

Maximum permissible working pressure 10 bar (water) / 5 bar (gas)



d/DN	Order No.	SDR range	D	L	Weight [kg]	BX	PU	Stock status
110/100	615569	17 - 26	130	160	0.700	24	192	1
160/150	615571	17 - 26	190	180	1.600	12	96	1
315/300	615576	17 - 26	355	300	7.700	1	18	1



MV SDR 11

Cap, SDR 11

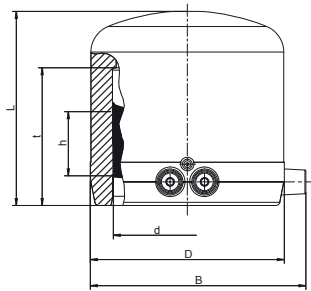

Cap MV SDR 11

- Gas, water and H₂
- Maximum pressure: Gas 10 bar; Water 16 bar
- Material; PE 100
- Safety technology
- DVGW test mark: DV-8601AU2248 and DV-8606AU2249

PE 100 SDR 11

Maximum permissible working pressure 16 bar (water) / 10 bar (gas)



d	Order No.	SDR range	D	L	Weight [kg]	BX	PU	Stock status
20	612025	11 - 17,6	31	62	0.035	50	2500	1
25	612026	11 - 17,6	35	65	0.040	50	2500	1
32	612027	11 - 17,6	44	70	0.060	60	1920	1
40	612028	11 - 17,6	55	75	0.090	50	1600	1
50	612029	11 - 17,6	67	80	0.125	30	960	1
63	612030	11 - 17,6	84	88	0.210	20	640	1
75	612031	11 - 17,6	99	99	0.320	20	640	1
90	612032	11 - 17,6	118	114	0.500	16	288	1
110	612033	11 - 17,6	143	125	0.825	12	216	1
125	612034	11 - 17,6	163	135	1.160	8	144	1
160	612035	11 - 17,6	208	160	2.240	10	60	1
180	616183	11 - 17,6	224	157	2.180	6	48	1
200	616184	11 - 17,6	250,6	167	3.000	4	32	1
225	616185	11 - 17,6	279	184	3.970	4	32	1



FRIALEN shapes

WS11 Elbow 11° with spigot

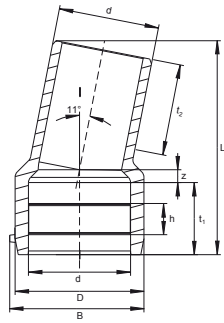

Elbow WS11 SDR 11 with spigot

- Gas, water and H2
- Maximum pressure: Gas 10 bar; Water 16 bar
- Material; PE 100
- Angle 11 degrees
- Universal direction alteration
- Multiple combination = elbow 22 degrees and 33 degrees can be implemented
- Safety technology
- DVGW test mark: DV-8606AU2249



PE 100 SDR 11

Maximum permissible working pressure 16 bar (water) / 10 bar (gas)

d	Order No.	D	L	Weight [kg]	BX	PU	Stock status
110	616139	141	235	0.920	8	144	1
125	616140	160	250	1.250	5	90	1
160	616141	200	295	2.260	8	64	1
180	616142	226	310	3.050	4	32	1
225	616143	280	350	5.280	1	18	1

W30 Elbow 30°

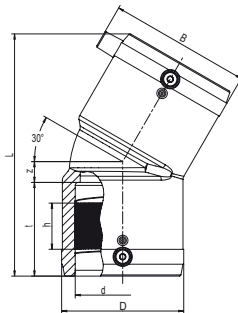

Elbow W30 SDR 11

- Gas, water and H2
- Maximum pressure: Gas 10 bar; Water 16 bar
- Material; PE 100
- Angle 30 degrees
- Safety technology
- DVGW test mark: DV-8606AU2249



PE 100 SDR 11

Maximum permissible working pressure 16 bar (water) / 10 bar (gas)

d	Order No.	D	L	Weight [kg]	BX	PU	Stock status
90	615272	115	224	0.780	8	144	1
110	615273	142	252	1.260	6	108	1
125	615274	158	270	1.640	4	72	1
160	615340	199	350	3.870	5	40	1
180	616261	229	390	4.990	3	24	1
200	616262	254	412	6.350	1	18	1
225	616263	281	456	8.220	1	18	1



W45

Elbow 45°

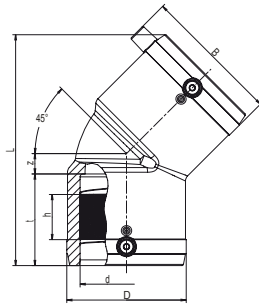

Elbow W45 SDR 11

- Gas, water and H2
- Maximum pressure: Gas 10 bar; Water 16 bar
- Material; PE 100
- Angle 45 degrees
- Safety technology
- DVGW test mark: DV-8601AU2248, DV-8606AU2249 and DV-8611AU2250

PE 100 SDR 11

Maximum permissible working pressure 16 bar (water) / 10 bar (gas)



d	Order No.	D	L	Weight [kg]	BX	PU	Stock status
25	616687	35	89	0.050	150	2400	1
32	612092	43	102	0.070	50	1600	1
40	612094	54	120	0.110	30	960	1
50	612096	66	136	0.175	20	640	1
63	612098	82	158	0.295	10	320	1
75	612100	96	198	0.520	14	252	1
90	612102	115	232	0.810	8	144	1
110	612104	138	265	1.320	10	80	1
125	612106	157	279	1.770	10	80	1
160	615275	207	377	4.410	4	32	1
180	615687	228	382	4.610	3	24	1
200	616264	254	415	6.760	1	18	1
225	615688	280	450	8.290	1	8	1
250	616404	310	621	17.300	1	6	1
280	616405	350	702	25.600	1	4	1
315	616406	396	755	36.000	1	2	1



FRIALEN shapes

W90

Elbow 90°

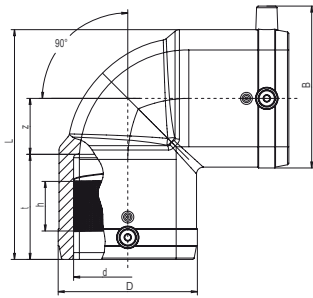

Elbow W90 SDR 11

- Gas, water and H₂
- Maximum pressure: Gas 10 bar; Water 16 bar
- Material; PE 100
- Angle 90 degrees
- Safety technology
- DVGW test mark: DV-8601AU2248, DV-8606AU2249 and DV-8611AU2250

PE 100 SDR 11

Maximum permissible working pressure 16 bar (water) / 10 bar (gas)



d	Order No.	D	L	Weight [kg]	BX	PU	Stock status
20	616686	28,5	71	0.040	200	3200	1
25	612091	37	73	0.060	60	1920	1
32	612093	43	82	0.070	50	1600	1
40	612095	53	96	0.110	30	960	1
50	612097	66	113	0.190	20	640	1
63	612099	83	136	0.340	10	320	1
75	612101	96	170	0.600	12	216	1
90	612103	115	202	0.950	6	108	1
110	612105	138	234	1.560	10	80	1
125	612107	157	254	2.030	8	64	1
160	615276	207	329	4.850	3	24	1
180	615689	228	354	5.760	3	24	1
200	616265	254	392	8.557	2	16	1
225	615690	280	430	10.220	1	8	1
250	616408	310	534	19.100	1	6	1
280	616409	350	621	27.500	1	2	1
315	616410	396	677	40.000	1	2	1

WET

Misalignment bridge

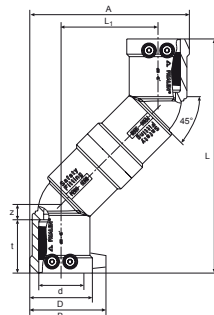

Misalignment bridge WET, SDR 11

- Gas, water and H₂
- Maximum pressure: Gas 10 bar; Water 16 bar
- Material; PE 100
- Bridging when the pipe alignment is offset
- Safety technology
- DVGW test mark: DV-8601AU2248

Note:

At the nominal size 63, 90 degree elbows are utilised.
Ideal for the parallel laying of two main pipes or for the house connection pipe to the tapping valve DAV or the tapping tees DAA.

PE 100 SDR 11

Maximum permissible working pressure 16 bar (water) / 10 bar (gas)



d	Order No.	D	L	L ₁	Weight [kg]	BX	PU	Stock status
32	616051	49	177	74	0.220	15	750	1
40	616052	58	215	89	0.330	15	480	1
50	616053	70	242	101	0.510	15	270	1
63	616699	84	172	172	0.670	10	180	1



FRIALEN shapes

WF

Elbow with base unit

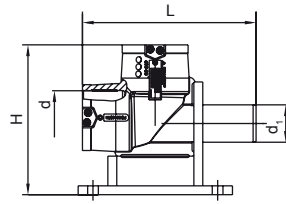

Elbow with base unit WF SDR 11

- Water
- Maximum pressure: 16 bar
- Material; PE 100
- Angle 90 degrees
- Assembly on the foundation possible
- Safety technology
- DVGW Registration No.: DV-8606AU2249

Note:

Ideal for the hydrant connection adjacent to main pipe. Extra spigot for connection to the house for continuous flow.

PE 100 SDR 11

Maximum permissible working pressure 16 bar (water)



d	d ₁	Order No.	H	L	Weight [kg]	BX	PU	Stock status
90	63	615989	253	293	2.250	3	54	1
110	63	615998	293	346	2.940	1	32	1

WFGB

BAIO Elbow with base unit

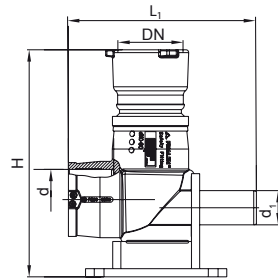

Elbow BAIO WFGB SDR 11 with base unit

- Water
- Maximum pressure: 16 bar
- Material; PE 100
- Angle 90 degrees
- BAIO socket connection made from cast iron (non-rotatable, non-detachable)
- Assembly on the foundation possible
- Safety technology

Note:

Ideal for hydrant connection with BAIO system next to the main pipe. Please observe the specific processing instructions for the BAIO system. Extra spigot for connection to the house for continuous flow.

PE 100 SDR 11

Maximum permissible working pressure 16 bar (water)



d/DN	d ₁	Order No.	H	L ₁	Weight [kg]	BX	PU	Stock status
110/80	63	616150	418	346	8.200	3	12	1

Minimum purchase quantity is a complete packaging unit (BX).



FRIALEN shapes

TA T-piece with spigot

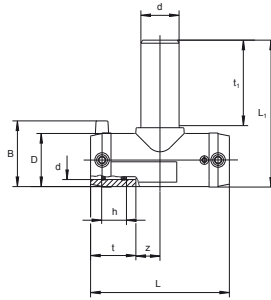

T-piece TA SDR 11 with spigot

- Gas, water and H₂
- Maximum pressure: Gas 10 bar; Water 16 bar
- Material; PE 100
- Spigot
- Safety technology
- DVGW test mark: DV-8601AU2248 and DV-8606AU2249

PE 100 SDR 11

Maximum permissible working pressure 16 bar (water) / 10 bar (gas)



With extra long outlet spigot

d	Order No.	D	L	L ₁	Weight [kg]	BX	PU	Stock status
20/20	616685	29	77	95	0.040	200	3200	1
25/25	616338	36	108	110	0.080	50	900	1
32/32	615719	44	116	131	0.120	35	630	1
40/40	615720	53	146	151	0.210	20	360	1
50/50	615721	67	175	186	0.358	10	180	1
63/63	615722	81	197	203	0.530	10	180	1

With standard outlet spigots

d	Order No.	D	L	L ₁	Weight [kg]	BX	PU	Stock status
90/90	616677	116	280	219	1.250	12	96	1
110/110	616680	141	310	247	1.950	6	48	1
160/160	616684	203	390	326	4.950	3	24	1



TA RED

T-piece with reduced spigot

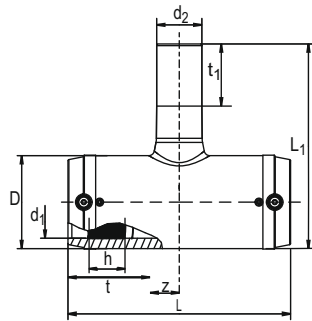

T-piece TA RED SDR 11 with reduced spigot

- Gas, water and H2
- Maximum pressure: Gas 10 bar; Water 16 bar
- Material; PE 100
- Reduced spigots
- Safety technology
- DVGW test mark: DV-8601AU2248, DV-8606AU2249 and DV-8611AU2250

PE 100 SDR 11

Maximum permissible working pressure 16 bar (water) / 10 bar (gas)



With long outlet spigot

d ₁	d ₂	Order No.	D	L	L1	Weight [kg]	BX	PU	Stock status
32	20	616417	46	116	117	0.110	30	540	1
40	32	616418	55	146	148	0.170	20	360	1
50	32	616419	69	175	158	0.295	10	180	1
50	40	616420	69	175	167	0.315	10	180	1
63	32	616421	84	197	173	0.435	10	180	1
63	40	616422	84	197	182	0.450	10	180	1
63	50	616423	84	197	197	0.490	10	180	1

With standard outlet spigots

d ₁	d ₂	Order No.	D	L	L1	Weight [kg]	BX	PU	Stock status
90	32	616675	116	280	172	1.050	17	136	1
90	63	616676	116	280	191	1.100	15	120	1
110	63	616678	141	310	216	1.700	8	64	1
110	90	616679	141	310	244	1.850	8	64	1
160	90	616681	203	390	305	4.400	4	32	1
160	110	616682	203	390	308	4.500	4	32	1
160	125	616683	203	390	313	4.600	3	24	1
250	225	616427	310	770	440	23.500	1	2	1
280	225	616429	350	905	475	35.500	1	2	3
315	225	616431	396	940	525	43.500	1	2	1



FRIALEN shapes

T T-piece

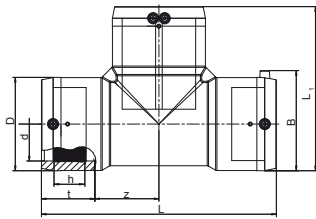

T-piece T SDR 11

- Gas, water and H₂
- Maximum pressure: Gas 10 bar; Water 16 bar
- Material; PE 100
- Safety technology
- DVGW test mark: DV-8606AU2249 and DV-8611AU2250

PE 100 SDR 11

Maximum permissible working pressure 16 bar (water) / 10 bar (gas)



d	Order No.	D	L	L ₁	Weight [kg]	BX	PU	Stock status
75	612165	96	278	187	0.980	8	144	1
90	612166	117	305	211	1.650	10	80	1
110	612167	142	355	248	2.580	6	48	1
125	612168	160	384	272	3.520	5	40	1
160	615277	200	430	315	5.820	3	24	1
180	615691	228	480	354	7.900	2	16	1
200	616266	251	550	400	11.130	1	8	1
225	615692	284	580	432	13.900	1	8	1
250	616412	310	770	540	27.400	1	4	1
280	616413	350	905	630	42.200	1	2	1
315	616414	396	940	670	55.900	1	1	1

TGB T-piece BAIO

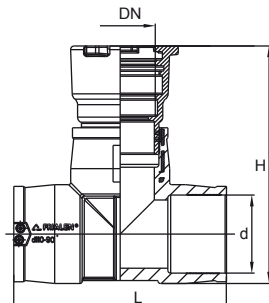

T-piece BAIO TGB SDR 11

- Water
- Maximum pressure: 16 bar
- Material; PE 100
- BAIO socket connection made from cast iron (non-releasable in terms of rotation)
- Safety technology

Note:

Ideal for hydrant connection with BAIO system next to the main pipe. Please observe the specific processing instructions for the BAIO system.

PE 100 SDR 11

Maximum permissible working pressure 16 bar (water)



d/DN	Order No.	H	L	Weight [kg]	BX	PU	Stock status
110/80	616147	337	302	7.530	4	16	1
125/80	616148	361	314	8.300	3	12	3
160/80	616149	380	390	12.000	2	8	1

Minimum purchase quantity is a complete packaging unit (BX).



FRIALEN shapes

TFL

Flange T-piece

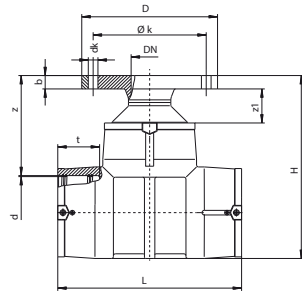

Flange T-piece TFL

- Water
- Maximum pressure: Water 16 bar (SDR 11), 10 bar (SDR 17)
- Material; PE 100 and metal insert
- Safety technology

Note:

Reduction and fusion flange. Metal insert in flange in order to prevent cold flow.

We recommend GST seals.

Note the screw tightening torques after specifying the seal manufacturer or DVS.

Additional washers are required.

PE 100 SDR 11

Maximum permissible working pressure 16 bar (water)



d/DN	Order No.	D	d _k	H	L	Ø k	Holes for screws	Weight [kg]	BX	PU	Stock status
110/80	615590	204	17.00	316	355	160	8	4.920	4	32	1
125/80	615591	204	17.00	343	384	160	8	5.480	3	24	1
160/80	615592	204	17.00	390	430	160	8	8.050	2	16	1
180/80	615910	204	17.00	416	480	160	8	10.000	1	8	1

PE 100 SDR 17

Maximum permissible working pressure 10 bar (water)



d/DN	Order No.	D	d _k	H	L	Ø k	Holes for screws	Weight [kg]	BX	PU	Stock status
225/80	616031	204	17.00	465	580	160	8	15.420	2	4	1



FRIALEN shapes

Y

Y-piece

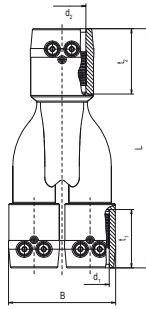

Y-piece Y SDR 11

- Gas and water
- Maximum pressure: Gas 10 bar; Water 16 bar
- Material; PE 100
- Safety technology
- DVGW test mark: DV-8601AU2248

PE 100 SDR 11

Maximum permissible working pressure 16 bar (water) / 10 bar (gas)



d	Order No.	L	Weight [kg]	BX	PU	Stock status
32-32-40	640034	205	0.230	28	504	1
40-40-50	640036	219	0.340	18	324	1

YS

Y-piece with spigot

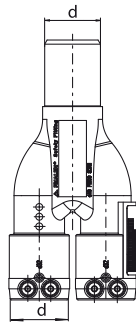

Y-piece YS SDR 11 with spigot

- Gas and water
- Maximum pressure: Gas 10 bar; Water 16 bar
- Material; PE 100
- Safety technology
- DVGW test mark: DV-8601AU2248

PE 100 SDR 11

Maximum permissible working pressure 16 bar (water) / 10 bar (gas)



d	Order No.	Weight [kg]	BX	PU	Stock status
32-32-40	640035	0.190	28	504	1
40-40-50	640037	0.300	18	324	1



DAV

Tapping valve RED SNAP, SDR 11

NEW

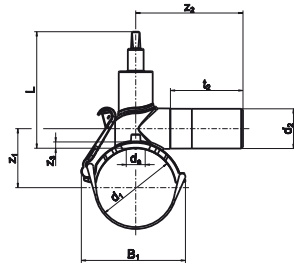

Tapping valve RED SNAP, SDR 11

- Gas, water and H2
- Maximum pressure: Gas 10 bar; Water 16 bar
- Material; PE 100
- Quick release mechanism (RED SNAP):
 - Simple and error-free assembly
 - More quality and high security
 - Save 50% of installation time
- Integrated drill with upper and lower inner stop
- Sealing plug with internal sealing O-ring
- Maximum 9 turns for opening and closing
- Safety technology
- DVGW test mark: DV-6611AU2255

Note:

For this purpose, there is a suitable actuating linkage DBS with KlickFix and foam rubber for wrench size SW14.

The output nominal size 63 / 40 is a solution with reducing socket MR.

When hydrogen (H2) is used, nothing else must be additionally built in.

PE 100 SDR 11

Maximum permissible working pressure 16 bar (water) / 10 bar (gas)



	d ₁	d ₂	Order No.	Drilling Ø d _a	L	Weight [kg]	BX	PU	Stock status
2)	50	32	617024	30	177	1.060	16	288	1
2)	63	32	617025	30	177	1.100	16	288	1
2)	63	40	617026	30	177	1.430	12	216	1
2)	63	63	616952	30	177	1.210	12	216	1
2)	75	32	617027	30	177	1.120	12	216	1
1)	90	32	616960	30	183	1.230	12	96	1
1)	90	40	616961	30	183	1.240	12	96	1
1)	90	50	616962	30	183	1.280	12	96	1
1)	90	63	616963	30	183	1.350	12	96	1
	110	32	616964	30	183	1.229	12	96	1
	110	40	616965	30	183	1.239	12	96	1
	110	50	616966	30	183	1.284	12	96	1
	110	63	616967	30	183	1.356	12	96	1
1)	125	32	616968	30	183	1.270	12	80	1
1)	125	40	616969	30	183	1.280	12	80	1
1)	125	50	616970	30	183	1.330	12	80	1
1)	125	63	616971	30	183	1.400	12	80	1
1)	140	32	616972	30	183	1.300	10	80	1
1)	140	63	616973	30	183	1.430	10	80	1
	160	32	616974	30	208	1.440	10	80	1
	160	40	616975	30	208	1.450	10	80	1
	160	50	616976	30	208	1.490	10	80	1
	160	63	616977	30	208	1.570	10	80	1
	180	32	616978	30	208	1.440	10	80	1
	180	40	616979	30	208	1.450	10	80	1
	180	50	616980	30	208	1.500	10	80	1
	180	63	616981	30	208	1.570	10	80	1
	200	32	616982	30	208	1.450	8	64	1
	200	63	616984	30	208	1.590	8	64	1
	225	32	616985	30	208	1.470	8	64	1
	225	40	616986	30	208	1.490	8	64	1
	225	50	616987	30	208	1.540	8	64	1
	225	63	616988	30	208	1.620	8	64	1

1) New product design with red lever available in Q1 2022.

2) New product design with red lever available in Q2 2022.



FRIALEN tapping tees

DAV

Tapping valves Classic, SDR 11

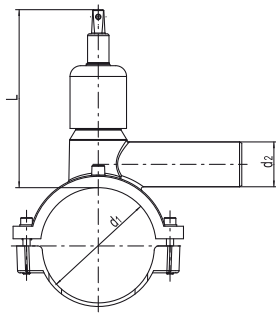

Tapping valves Classic, SDR 11

- Gas and water
- Maximum pressure: Gas 10 bar; Water 16 bar
- Material; PE 100
- Conventional clamping technology (brackets and screws)
- Integrated drill with upper and lower inner stop
- Sealing plug with internal sealing O-ring
- Maximum 10 turns for opening and closing
- Safety technology
- DVGW test mark: DV-6611AU2255

Note:

For this purpose, there is a suitable actuating linkage DBS with KlickFix and foam rubber for wrench size SW14.

The outputs nominal size 90 / 40 and 125 / 40 are a solution with reducing socket MR.

When hydrogen (H2) is used, nothing else must be additionally built in.



PE 100 SDR 11

Maximum permissible working pressure 16 bar (water) / 10 bar (gas)

	d ₁	d ₂	Order No.	Drilling Ø d _a	L	Weight [kg]	BX	PU	Stock status
2)	50	32	615955	20	164	1.310	16	288	1
2)	63	32	615341	20	164	0.950	16	288	1
2)	63	40	615342	20	164	0.970	16	288	1
2)	75	32	615956	20	164	1.390	12	216	1
1)	90	32	615344	30	200	1.750	12	96	1
1)	90	40	615617	30	200	1.970	12	96	1
1)	90	50	615346	30	200	1.800	12	96	1
1)	90	63	615347	30	200	1.870	12	96	1
1)	125	32	615352	30	200	2.185	10	80	1
1)	125	40	615625	30	200	2.385	10	80	1
1)	125	50	615354	30	200	2.245	10	80	1
1)	125	63	615355	30	200	2.320	10	80	1
1)	140	63	615930	30	200	2.290	10	80	1

1) Discontinued item, available until end of 3rd quarter 2022

2) Discontinued item, available until end of 4th quarter 2022

DBS

Installation kit for tapping valves

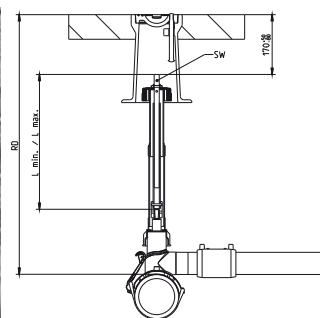

Installation kit DBS

- To operate the DAV RED SNAP from the road cap downwards
- KlickFix (tool-free) with foam rubber
- Wrench size SW14 (14 mm)
- Telescopic bar:
 - Length fitting
 - Continuously adjustable (without tools)
- Self-supporting
- Corrosion free

Note:

The installation kit DBS is suitable for use with FRIALEN tapping valves DAV Classic and DAV RED SNAP.

RD [m]	Order No.	SW ₁	Weight [kg]	BX	PU	Stock status
0,7-1,0	616999	14	2.150	1	42	1
0,9-1,3	617000	14	2.650	1	42	1
1,2-1,8	617001	14	3.600	1	42	1
1,8-2,7	617002	14	3.600	1	42	3
2,6-3,5	617003	14	4.500	1	42	3



DAV TL

Top-loading tapping valve, SDR 11

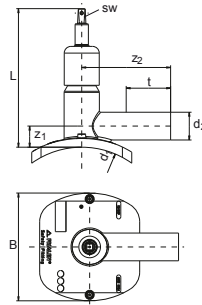

Top-loading tapping valve DAV TL SDR 11

- Gas and water
- Maximum pressure: Gas 10 bar; Water 16 bar
- Material; PE 100
- Universal clamping option (top loading):
 - Safe clamping with FRIATOP
 - Universal adaptation to pipe diameter
- Integrated drill with upper and lower inner stop
- Sealing plug with internal sealing O-ring
- Maximum 10 turns for opening and closing
- Safety technology
- ÖVGW test mark: G2.318, GRISW1.256

Note:

Can only be fused with the clamping device FRIATOP (Order No. 613350).
 For this purpose, there is a suitable actuating linkage DBS with KlickFix and foam rubber for wrench size SW14 (14 mm).
 When hydrogen (H2) is used, nothing else must be additionally built in.



PE 100 SDR 11

Maximum permissible working pressure 16 bar (water) / 10 bar (gas)



d ₁	d ₂	Order No.	Drilling Ø d _a	L	Weight [kg]	BX	PU	Stock status
250-315	63	616464	30	251	2.455	7	56	1
355-400	63	616465	30	251	2.459	7	56	1

DAA

Tapping tee RED SNAP, SDR 11

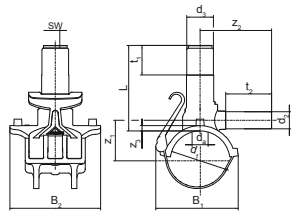

Tapping tee DAA SDR 11

- Gas, water and H2
- Maximum pressure: Gas 10 bar; Water 16 bar
- Material; PE 100
- Quick release mechanism (RED SNAP):
 - Simple and error-free assembly
 - Increased quality and safety
 - Save 50% of installation time
- Integrated drill with upper and lower inner stop
- Sealing plug with internal sealing O-ring
- Safety technology
- DVGW test mark: DV-6611CS007



Note:

Only utilise one actuating key FWSS SW 17 (Order No. 613246) for all dimensions.

There is a suitable pressure test adapter FWDPA for DAA RED SNAP (Order No. 613597).

All outlets d2 with nominal size 40 and 50 are always a solution with reducing socket MR.

When using hydrogen (H2), the tapping tees DAA must be fitted with a cap DK (Order No. 612310).

PE 100 SDR 11

Maximum permissible working pressure 16 bar (water) / 10 bar (gas)



d ₁	d ₂	Order No.	d ₃	Drilling Ø d _a	L	Weight [kg]	BX	PU	Stock status
40	20	612630	50	25	120	0.370	30	240	1
40	25	616473	50	25	120	0.380	30	240	1
40	32	616474	50	25	120	0.385	30	240	1
50	20	616475	50	25	120	0.385	28	224	1
50	25	612702	50	25	120	0.390	28	224	1
50	32	615080	50	25	120	0.400	28	224	1
63	20	612631	50	25	130	0.450	20	160	1
63	25	612633	50	25	130	0.460	20	160	1
63	32	612632	50	25	130	0.465	20	160	1
63	40	616472	50	30	160	0.855	16	128	1
63	63	616334	50	30	160	0.635	16	128	1
75	32	616482	50	25	130	0.485	24	192	1
90	20	616483	50	30	160	0.600	14	112	1
90	25	616484	50	30	160	0.610	14	112	1
90	32	612634	50	30	160	0.615	14	112	1
90	40	615656	50	30	160	0.950	14	112	1
90	50	616476	50	30	160	0.960	14	112	1
90	63	612701	50	30	160	0.730	14	112	1
110	20	616487	50	30	160	0.620	14	112	1
110	25	616488	50	30	160	0.625	14	112	1
110	32	612637	50	30	160	0.630	14	112	1
110	40	615662	50	30	160	1.000	14	112	1
110	50	616477	50	30	160	1.010	14	112	1
110	63	612624	50	30	160	0.780	14	112	1
125	20	616491	50	30	160	0.650	12	96	1
125	25	616492	50	30	160	0.655	12	96	1
125	32	612649	50	30	160	0.670	12	96	1
125	40	615668	50	30	160	1.020	12	96	1
125	50	616478	50	30	160	1.030	12	96	1
125	63	612309	50	30	160	0.800	12	96	1
140	32	616495	50	30	160	0.700	12	96	1
140	63	616496	50	30	160	0.830	12	96	1
160	20	616497	50	30	160	0.730	10	80	1
160	25	616498	50	30	160	0.735	10	80	1
160	32	612641	50	30	160	0.745	10	80	1
160	40	615675	50	30	160	1.095	10	80	1
160	50	616480	50	30	160	1.105	10	80	1
160	63	612650	50	30	160	0.875	10	80	1



FRIALEN tapping tees

DAA Pressure Tapping tee RED SNAP, SDR 11

PE 100 SDR 11

Maximum permissible working pressure 16 bar (water) / 10 bar (gas)



d ₁	d ₂	Order No.	d ₃	Drilling Ø d _a	L	Weight [kg]	BX	PU	Stock status
180	20	616501	50	30	190	0.785	10	80	3
180	25	616502	50	30	190	0.790	10	80	1
180	32	612651	50	30	190	0.790	10	80	1
180	50	616481	50	30	190	1.170	10	80	1
180	63	612652	50	30	190	0.940	10	80	1
200	32	612654	50	30	190	0.810	8	64	1
200	63	612659	50	30	190	0.950	8	64	1
225	32	612657	50	30	190	0.835	8	64	1
225	50	616486	50	30	190	1.210	8	64	1
225	63	612655	50	30	190	0.980	8	64	1

DAA TL Top-loading tapping tee, SDR 11

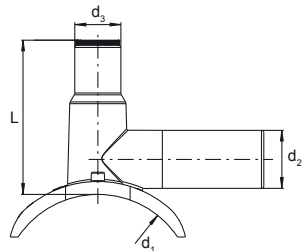

Top-loading tapping tee DAA TL SDR 11

- Gas and water
- Maximum pressure: Gas 10 bar; Water 16 bar
- Material; PE 100
- Universal clamping option (top loading):
 - Safe clamping with FRIATOP
 - Universal adaptation to pipe diameter
- Leak test possible before drilling
- Integrated drill with upper and lower inner stop
- Sealing plug with internal sealing O-ring
- Safety technology
- DVGW test mark: DV-8606AU2249 and DV-8611AU2250

Note:

Can only be fused with the clamping device FRIATOP (Order No. 616650). Only one actuating key FWSS SW 19 (Order No. 613250) for all dimensions.
 There is a suitable pressure test adapter FWDPA for DAA TL (Order No. 613595).
 When using hydrogen (H₂), the tapping tees DAA must be fitted with a cap DK (Order No. 612310).
 From nominal size 315 to 400, the DAA TL is only suitable for SDR 17 pipes.



PE 100 SDR 11

Maximum permissible working pressure 16 bar (water) / 10 bar (gas)



d ₁	d ₂	Order No.	d ₃	Drilling Ø d _a	L	Weight [kg]	BX	PU	Stock status
250-315 (- 400)	63	615339	50	30	167	1.360	4	72	1



FRIALEN tapping tees

DAP

Vertical tapping tee, SDR 11

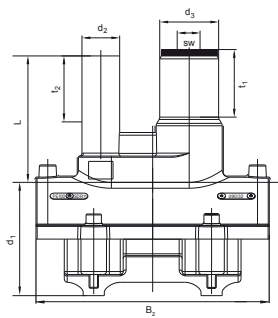

Vertical tapping tee DAP SDR 11

- Gas and water
- Maximum pressure: Gas 10 bar; Water 16 bar
- Material; PE 100
- Conventional clamping technology (brackets and screws)
- Vertical outlet for special solutions:
 - Space-saving installation
 - With 90 degree elbow and ball valve = Rotatable dome 360 degrees
- Leak test possible before drilling.
- Integrated drill with upper and lower inner stop
- Sealing plug with internal sealing O-ring
- Safety technology
- DVGW test mark: DV-8601AU2248 and DV-8606AU2249

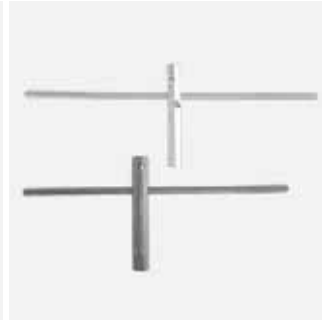

Note:

Utilise the operating key FWSS SW 17 for d 63 (Order No. 613246) or FWSS SW 19 from d 90 (Order No. 613250).

There is a suitable pressure test adapter FWDPA for DAP (Order No. 613595).

When using hydrogen (H₂), the tapping tees DAA must be fitted with a cap DK (Order No. 612310).



PE 100 SDR 11

Maximum permissible working pressure 16 bar (water) / 10 bar (gas)

d ₁	d ₂	Order No.	d ₃	Drilling Ø d _a	L	Weight [kg]	BX	PU	Stock status
63	32	616042	40	21	125	0.630	16	288	1
110	32	615581	50	30	158	1.280	12	96	1
110	50	615606	50	30	158	1.380	12	96	1
125	32	615711	50	30	158	1.310	12	96	1
125	50	615712	50	30	158	1.360	12	96	1
160	32	615713	50	30	170	1.540	8	64	1
160	50	615714	50	30	170	1.560	8	64	1
180	32	615715	50	30	170	1.540	6	48	1
180	50	615716	50	30	170	1.560	6	48	1
1) 225	32	615717	50	30	170	1.570	6	48	3
225	50	615718	50	30	170	1.590	6	48	1

1) Minimum purchase quantity is a complete packaging unit (BX).

DK

Cap for tapping tees, SDR 11

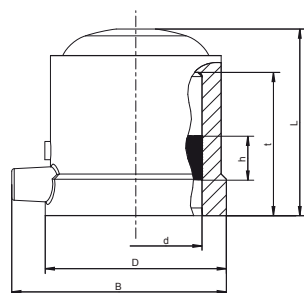

Cap for tapping tees DK SDR 11

- Gas, water and H₂
- Maximum pressure: Gas 10 bar; Water 16 bar
- Material; PE 100
- Safety technology
- DVGW test mark: DV-8601AU2248

Note:

When using hydrogen (H₂), the tapping tees DAA, DAA TL and DAP must be fitted with a closure cap DK.



PE 100 SDR 11

Maximum permissible working pressure 16 bar (water) / 10 bar (gas)

d	Order No.	D	L	Weight [kg]	BX	PU	Stock status
50	612310	69	72	0.110	30	960	1



FRIALEN tapping tees

GAB

Purge stack for venting gas pipes



Purge stack GAB for venting PE gas pipes

- Gas and H₂
- Maximum pressure: 10 bar
- Material; PE 100
- Blow-out aperture: 1" and 2"
- With DAV (RED SNAP)
- Telescopic bar:
 - Length adjustment
 - Continuously adjustable (without tools)
- Maximum 9 turns for opening and closing
- Safety technology
- DVGW test mark: DV-6611AU2255

Note:

The GAB is delivered without additional tools.

PE 100 SDR 11

Maximum permissible working pressure 10 bar (gas)



	d ₁	R	RD [m]	Order No.	Weight [kg]	BX	PU	Stock status
	63	1"	0,7 - 1,0	2006380	4.440	1	1	3
	63	2"	0,7 - 1,0	2006383	6.710	1	1	3
	90	1"	0,7 - 1,0	2009080	5.240	1	1	3
	90	2"	0,7 - 1,0	2009083	7.400	1	1	3
1)	110	1"	0,7 - 1,0	2011080	4.740	1	1	3
1)	110	2"	0,7 - 1,0	2011083	6.800	1	1	3
	125	1"	0,7 - 1,0	2012580	5.700	1	1	3
	125	2"	0,7 - 1,0	2012583	7.850	1	1	3
	160	1"	0,7 - 1,0	2016080	6.200	1	1	3
	160	2"	0,7 - 1,0	2016083	8.330	1	1	3
	180	1"	0,7 - 1,0	2018080	6.200	1	1	3
	180	2"	0,7 - 1,0	2018083	8.340	1	1	3
	225	1"	0,7 - 1,0	2022580	6.300	1	1	3
	225	2"	0,7 - 1,0	2022583	8.440	1	1	3

1) Including DAV RED SNAP



FRIALEN valves

FRIASTOP M Gas-Stop SENTRI GS by Maxitrol

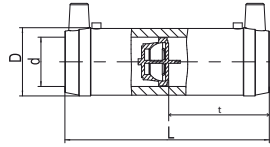

Gas-Stop FRIASTOP with SENTRI GS System by Maxitrol

- Gas and H₂ (20 %)
- Maximum pressure:
 - Type Z and B 0.5 bar gas
 - Type D 1 bar gas
- Material; PE 100
- Overflow device for Type D and Z
- Function with admixture of 20 % hydrogen
- Safety technology
- DVGW test mark: DV-8601AU2248 and DG-4360BO0438

PE 100 SDR 11

Maximum permissible working pressure Type Z, B: 5 bar (gas), Type D: 1 bar (gas)



d	Operating pressure range $p_{min} - p_{max}$	Order No.	Type	D	L	VN	Weight [kg]	BX	PU	Stock status
32	35 mbar - 5 bar	616187	Z	45	136	17 - 40	0.140	40	1280	1
40	35 mbar - 5 bar	616188	Z	54	146	26 - 62	0.220	30	960	1
50	35 mbar - 5 bar	616189	Z	68	175	41 - 99	0.380	16	512	1
63	35 mbar - 5 bar	616190	Z	82	197	66 - 158	0.530	10	320	1
32	25 mbar - 1 bar	616191	D	45	136	11 - 16	0.140	40	1280	1
40	25 mbar - 1 bar	616193	D	54	146	19 - 27	0.220	30	960	3
50	25 mbar - 1 bar	616195	D	68	175	28 - 40	0.380	16	512	1
63	25 mbar - 1 bar	616197	D	82	197	51 - 72	0.530	10	320	1
32	100 mbar - 5 bar	616192	B	45	136	26 - 60	0.140	40	1280	1

Acceptance only in complete packaging units.

FRIASTOP P Gas-Stop by Pipelife

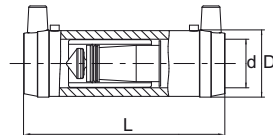

Gas-Stop FRIASTOP with integrated Gas-Stop System by Pipelife

- Gas and H₂ (30 %)
- Maximum pressure:
 - Type U, UUE and S 5 bar gas
 - Type A/D 1 bar gas
- Material; PE 100
- Overflow device for Type A/D, UUE and S
- Function to admixture of 30 % hydrogen
- Safety technology
- DVGW test mark: DV-8601AU2248 and DG-4360BP0060 (DVGW G 5305-2)

PE 100 SDR 11

Maximum permissible working pressure Type U, UUE, S: 5 bar (gas), Type A/D: 1 bar (gas)



d	Operating pressure range $p_{min} - p_{max}$	Order No.	Type	D	L	VN	Weight [kg]	BX	PU	Stock status
32	35 mbar - 5 bar	616199	U	45	136	16 - 38	0.140	40	1280	1
50	35 mbar - 5 bar	616201	U	68	175	38 - 91	0.350	20	640	1
63	35 mbar - 5 bar	616203	U	82	197	58 - 140	0.560	12	384	1
32	35 mbar - 5 bar	616200	UUE	45	136	16 - 38	0.140	40	1280	1
50	35 mbar - 5 bar	616202	UUE	68	175	38 - 91	0.350	20	640	1
63	35 mbar - 5 bar	616204	UUE	82	197	58 - 140	0.560	12	384	1
32	25 mbar - 1 bar	616205	A/D	45	136	10 - 14	0.140	40	1280	1
50	25 mbar - 1 bar	616207	A/D	68	175	25 - 36	0.350	20	640	1
63	25 mbar - 1 bar	616209	A/D	82	197	40 - 55	0.560	12	384	1
32	200 mbar - 5 bar	616339	S	45	136	36 - 80	0.140	40	1280	1
50	200 mbar - 5 bar	616340	S	68	175	110 - 240	0.350	20	640	3
63	200 mbar - 5 bar	616341	S	82	197	180 - 400	0.560	12	384	3

Acceptance only in complete packaging units.



MR STOP

Gas-Stop SENTRI GS by Maxitrol in Reducer

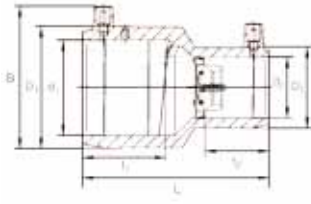

Gas-Stop MR STOP with SENTRI GS System by Maxitrol in Reducer

- Gas and H₂ (20 %)
- Maximum pressure:
 - Type Z 5 bar gas
 - Type D 1 bar gas
- Material; PE 100
- Overflow device for Type Z and D
- Function with admixture of 20 % hydrogen
- Safety technology
- DVGW test mark: DV-8601AU2248 and DG-4360BO0438

PE 100 SDR 11

Maximum permissible working pressure Type Z: 5 bar (gas), Type D: 1 bar (gas)



d ₁	d ₂	Operating pressure range p _{min} - p _{max}	Order No.	Type	D ₁ /D ₂	L	VN	Weight [kg]	BX	PU	Stock status
50	40	35 mbar - 5 bar	616218	Z	68/54	110	26 - 62	0.210	12	600	3
63	32	35 mbar - 5 bar	616219	Z	82/45	125	17 - 40	0.240	18	576	1
63	40	35 mbar - 5 bar	616220	Z	82/54	125	26 - 62	0.290	8	400	3
63	50	35 mbar - 5 bar	616221	Z	82/68	125	41 - 99	0.360	8	400	1
63	32	25 mbar - 1 bar	616238	D	82/45	125	11 - 16	0.240	10	500	1
63	50	25 mbar - 1 bar	616240	D	82/68	125	28 - 40	0.360	16	512	1

Acceptance only in complete packaging units.



FRIALEN valves

FRIALOC

PE shut-off valve without flow losses

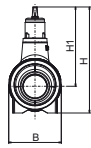
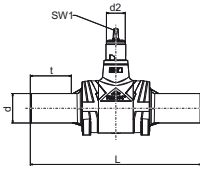

Shut-off valve FRIALOC

- Water
- Maximum pressure: 16 bar
- Material; PE 100
- Double shut-off function
- No cavities and stagnation
- No flow losses
- Maximum 14 turns for opening and closing
- DVGW test mark: DW-6210BT0171

Note:

The nominal sizes 200 to 250 have a restricted passage of d 180.
There is a suitable installation kit FBS with KlickFix for wrench size SW19 (19 mm).

PE 100 SDR 11

Maximum permissible working pressure 16 bar (water)



d	d ₂	Order No.	H	L	SW ₁	Weight [kg]	BX	PU	Stock status
90	80	616293	450	720	19	13.900	1	8	1
110	80	616294	450	720	19	14.200	1	8	1
125	80	616295	450	720	19	14.500	1	8	1
160	80	616296	608	1010	19	44.000	1	2	1
180	80	616297	608	1030	19	39.000	1	2	1
200	80	616453	608	1030	19	40.500		2	3
225	80	616298	608	1030	19	40.500	1	2	1
250	80	616438	608	1030	19	41.940		2	3

The minimum purchase quantity is one pallet unit (PU).

FRIALOC

PE shut-off valve without flow losses (closing in a clockwise direction)

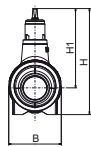
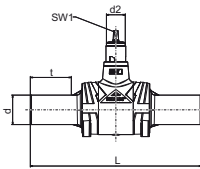

Shut-off valve FRIALOC ACW

- Water
- Maximum pressure: 16 bar
- Material; PE 100
- Double shut-off function
- No cavities and stagnation
- No flow losses
- Maximum 14 turns for opening and closing
- Closing operation, anti-clockwise
- DVGW test mark: DW-6210BT0171

Note:

The nominal sizes 200 to 225 have a limited passage of d 180.
There is a suitable installation kit FBS with KlickFix for wrench size SW19 (19 mm).

PE 100 SDR 11

Maximum permissible working pressure 16 bar (water)



d	d ₂	Order No.	H	L	SW ₁	Weight [kg]	BX	PU	Stock status
90	80	616991	450	720	19	13.900	1	8	1
110	80	616992	450	720	19	14.200	1	8	1
125	80	616993	450	720	19	14.500	1	8	1
160	80	616994	608	1010	19	44.000	1	2	1
180	80	616995	608	1030	19	39.000	1	2	1
200	80	616996	608	1030	19	40.500	1	2	3
225	80	616997	608	1030	19	40.500	1	2	1

The minimum purchase quantity is one pallet unit (PU).



FRIALEN valves

FBS

Actuating linkage for FRIALOC PE shut-off valves

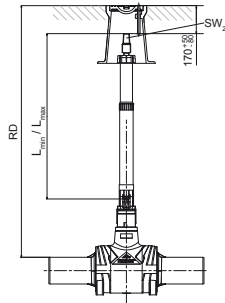

Actuating linkage FBS for FRIALOC

- To operate the FRIALOC from the road cap downwards
- ClickFix (tool-free)
- Wrench size SW19 (19 mm)
- Telescopic bar:
 - Length fitting
 - Continuously adjustable (without tools)
- Self-supporting
- Corrosion free

Steel linkage, hot-dipped galvanised

RD [m]	Order No.	SW ₂	Weight [kg]	BX	PU	Stock status
0,75 - 1,0	616308	30	2.500	1	42	1
0,9 - 1,3	616309	30	2.950	1	42	1
1,2 - 1,8	616310	30	3.850	1	42	1
1,5 - 2,3	616318	30	4.400	1	42	1

Stainless steel linkage

RD [m]	Order No.	SW ₂	Weight [kg]	BX	PU	Stock status
0,75 - 1,0	616315	30	2.400	1	42	3
0,9 - 1,3	616316	30	2.800	1	42	1
1,2 - 1,8	616317	30	3.450	1	42	1
1,5 - 2,3	616319	30	4.150	1	42	3

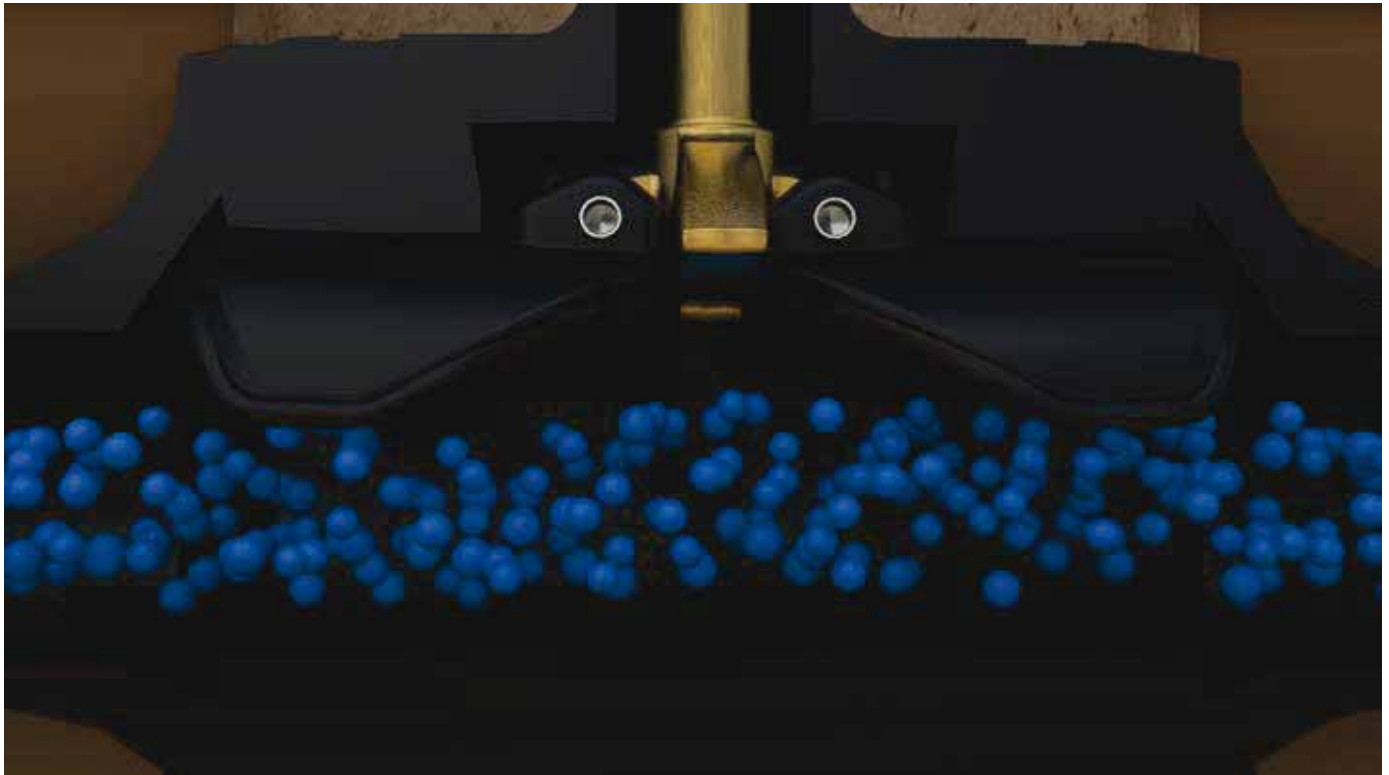

FRIALEN valves

KHP

Ball valve for gas

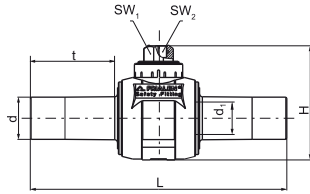

Ball valve for gas KHP

- Gas and H2
- Maximum pressure: 10 bar
- Material; PE 100
- Gasket: NBR
- 1/4 turns for opening and closing
- DVGW test mark: DG-8631AU2251, DG-8631AU2252 and DG-8631AU2253

Note:

For this purpose, there is a suitable actuating rod KBS for wrench sizes SW14 (14 mm) and SW30 (30 mm).

PE 100 SDR 11

Maximum permissible working pressure 10 bar (gas)



d	d ₁	Order No.	H	L	SW ₁	SW ₂	Weight [kg]	BX	PU	Stock status
32	24	612490	136	310	50 x 50	20	0.540	1	170	1
40	24	612497	136	310	50 x 50	20	0.580	1	170	1
50	24	612492	136	310	50 x 50	20	0.680	1	170	1
63	43	612494	193	410	50 x 50	25	2.300	1	50	1
90	67	612495	241	553	50 x 50	25	4.200	1	24	1
110	67	612493	241	553	50 x 50	25	4.500	1	24	1
125	67	612496	241	553	50 x 50	25	5.200	1	24	1
160	98	612483	332	539	50 x 50	25	12.000	1	8	1
180	98	615309	332	539	50 x 50	25	12.500	1	8	1
200	98	612480	332	539	50 x 50	25	13.500	1	8	1
225	98	616186	332	539	50 x 50	25	14.500	1	8	1

KH

Ball valve for gas without flow losses

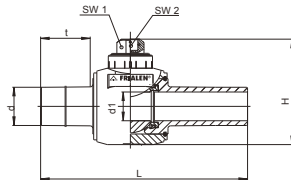

Ball valve for gas KH without flow losses

- Gas and H2
- Maximum pressure: 10 bar
- Material; PE 100
- Gasket: NBR
- No flow losses
- 1/4 turns for opening and closing
- DVGW test mark: DG-8631AU2251 and DG-8631AU2252

Note:

For this purpose, there is a suitable actuating linkage KBS for wrench sizes SW14 (14 mm) and SW30 (30 mm).
From nominal size 50, utilise a KBS d 63 - d 225.

PE 100 SDR 11

Maximum permissible working pressure 10 bar (gas)



d	d ₁	Order No.	H	L	SW ₁	SW ₂	Weight [kg]	BX	PU	Stock status
20	24	616470	138	310	50 x 50	20	0.500	1	170	3
25	24	616471	138	310	50 x 50	20	0.550	1	170	1
32	34	616176	156	324	50 x 50	20	0.770	1	100	1
40	34	616177	156	324	50 x 50	20	0.800	1	100	1
50	43	616178	193	405	50 x 50	25	2.240	1	50	1
63	51	616179	206	410	50 x 50	25	2.420	1	50	1
90	98	616180	288	577	50 x 50	25	6.600	1	18	1
110	98	616181	288	577	50 x 50	25	6.750	1	18	1
125	98	616182	288	577	50 x 50	25	6.900	1	18	1



FRIALEN valves

KHW

Ball valve for water

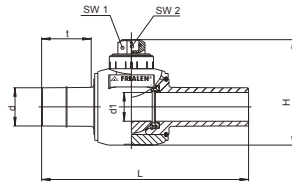

Ball valve KHW for water

- Water
- Maximum pressure: 16 bar
- Material: PE 100
- Gasket: EPDM
- 1/4 turns for opening and closing
- DVGW test mark: DW-6210CQ0059

Note:

For this purpose, there is a suitable actuating linkage KBS for wrench sizes SW14 (14 mm) and SW30 (30 mm).
From nominal size 50, utilise a KBS d 63 - d 225.

PE 100 SDR 11

Maximum permissible working pressure 16 bar (water)



d	d ₁	Order No.	H	L	SW ₁	SW ₂	Weight [kg]	BX	PU	Stock status
32	34	616656	156	324	50 x 50	20	0.770	1	100	1
40	34	616657	156	324	50 x 50	20	0.800	1	100	1
50	43	616658	193	405	50 x 50	25	2.240	1	50	1
63	51	616659	206	410	50 x 50	25	2.420	1	50	1

AKHP

Tapping ball valve for side tapping gas under pressure

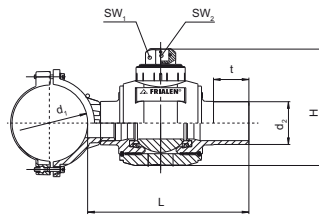

Tapping ball valve AKHP for gas

- Gas and H₂
- Maximum pressure: 10 bar
- Material: PE 100
- Gasket: NBR
- 1/4 turns for opening and closing
- Saddle component with clamp
- Safety technology
- DVGW test mark: DG-8631AU2252 and DG-8631AU2253

Note:

For this purpose, there is a suitable actuating linkage KBS for wrench sizes SW14 (14 mm) and SW30 (30 mm).
For tapping under pressure, we recommend the tapping tool from Hütz & Baumgarten (www.huetz-baumgarten.de).

PE 100 SDR 11

Maximum permissible working pressure 10 bar (gas)



d ₁	d ₂	Order No.	Drilling Ø d _a	H	L	SW ₁	SW ₂	Weight [kg]	BX	PU	Stock status
110	63	615427	42	180	330	50 x 50	25	3.070	6	48	1
110	90	615428	60	240	335	50 x 50	25	4.670	4	32	1
125	90	615431	60	240	335	50 x 50	25	4.790	4	32	1
160	63	615433	42	180	330	50 x 50	25	3.300	4	32	1
160	90	615434	60	240	335	50 x 50	25	5.000	4	32	1
180	90	615437	60	240	335	50 x 50	25	5.000	4	32	1
225	90	615440	60	240	335	50 x 50	25	5.000	4	32	1



FRIALEN valves

AKHP TL

Tapping ball valve Top loading for gas for side tapping under pressure

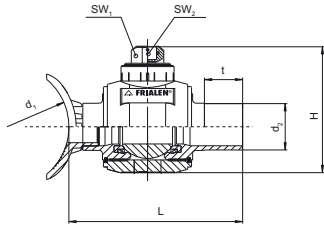

Tapping ball valve AKHP TL for gas

- Gas and H2
- Maximum pressure: 10 bar
- Material: PE 100
- Gasket: NBR
- 1/4 turns for opening and closing
- Top load saddle
- Safety technology
- DVGW test mark: DG-8631AU2252 and DG-8631AU2253

Note:

Can only be fused with the clamping device FRIATOP (Order No. 613350). For this purpose, there is a suitable actuating linkage KBS for wrench sizes SW14 (14 mm) and SW30 (30 mm).

For drilling under pressure, we recommend the drilling tool from Hütz & Baumgarten (www.huetz-baumgarten.de).

From nominal size 450 to 560 only suitable for SDR17.



PE 100 SDR 11

Maximum permissible working pressure 10 bar (gas)



d ₁	d ₂	Order No.	Drilling Ø d _a	H	L	SW ₁	SW ₂	Weight [kg]	BX	PU	Stock status
250-450 (- 560)	90	615526	60	240	335	50 x 50	25	4.470	4	32	1

KBS

Actuating linkage for ball valves

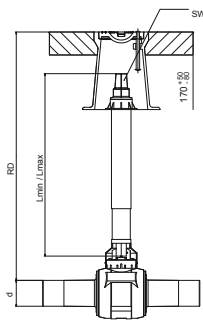

Actuating linkage KBS for ball valves

- To operate the ball valves from the road cap downwards
- Wrench size SW14 (14 mm) and SW30 (30 mm)
- Telescopic bar:
 - Length fitting
 - Continuously adjustable (without tools)
- Self-supporting
- Corrosion free

Note:

Stable seating for the sleeve pipe bell at the nominal size of 20-50, by means of a design comprising a housing.

d	RD [m]	Order No.	SW ₁	Weight [kg]	BX	PU	Stock status
20-50	0,45-0,70	615741	30	1.800	1	42	1
20-50	0,60-1,00	615957	14	2.700	1	42	1
20-50	0,60-1,00	615328	30	2.000	1	42	1
20-50	1,00-1,50	616466	14	3.400	1	42	1
20-50	1,00-1,50	615330	30	3.400	1	42	1
20-50	1,20-2,00	616068	14	3.450	1	42	1
20-50	1,20-2,00	615329	30	3.650	1	42	1
63-225	0,60-1,00	615958	14	2.050	1	42	1
63-225	0,60-1,00	615310	30	3.050	1	42	1
63-225	1,00-1,50	616467	14	4.150	1	42	1
63-225	1,00-1,50	615331	30	4.150	1	42	1
63-225	1,20-2,00	616069	14	3.600	1	42	1
63-225	1,20-2,00	615311	30	5.250	1	42	1



FRIALEN saddles

SA

Saddle with spigot, SDR 11

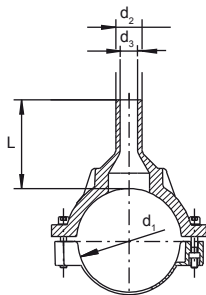

Saddle with spigot SA SDR 11

- Gas, water and H₂
- Maximum pressure: Gas 10 bar; Water 16 bar
- Material; PE 100
- Saddle component with clamp
- Tapping under pressure possible
- Safety technology
- DVGW test mark: DV-8601AU2248 and DV-8606AU2249.

Note:

For the pressure-free tapping, there is our drilling device FWAB.

For tapping under pressure, we recommend the drilling tool from Hütz & Baumgarten (www.huetz-baumgarten.de).

If required, please contact our hotline: +49 621 486-2325.

PE 100 SDR 11

Maximum permissible working pressure 16 bar (water) / 10 bar (gas)



d ₁	d ₂	Order No.	d ₃	Drilling Ø d _a	L	Weight [kg]	BX	PU	Stock status
63	32	612757	22	20	100	0.330	20	360	1
63	50	612759	37	36	113	0.370	20	360	1
75	50	615020	38	36	82	0.430	15	270	1
90	32	615285	21	20	103	0.700	20	160	1
90	63	612819	50	46	103	0.720	20	160	1
110	32	615334	24	20	125	0.788	12	96	1
110	50	615031	39	36	132	0.816	12	96	1
110	63	612760	49	46	150	0.868	12	96	1
110	90	615411	70	65	115	0.960	12	96	1
125	32	615087	21	20	109	0.945	12	96	1
125	63	612761	47	46	109	0.990	12	96	1
125	90	615412	70	65	116	1.080	12	96	1
125	110	615584	86	84	116	1.150	10	80	1
160	32	612886	21	20	126	1.440	8	64	1
160	63	612762	47	46	140	1.520	6	48	1
160	90	615413	70	65	140	1.640	2	36	1
160	110	615739	86	84	140	1.765	2	36	1
160	125	615585	98	95	140	1.880	2	36	1
180	63	612763	47	46	109	1.190	6	48	1
180	90	615414	70	65	116	1.820	2	36	1
180	110	615948	86	84	136	1.960	2	36	1
180	125	615740	98	95	141	2.110	2	36	1
200	63	612764	47	46	109	1.260	5	40	1
225	63	612765	47	46	109	1.210	5	40	1
225	90	615415	70	65	130	1.950	5	40	1
225	110	616044	86	84	140	1.960	5	40	1
225	125	616045	97	95	146	2.240	4	32	1
225	160	616046	125	123	157	2.580	4	32	1



FRIALEN saddles

SAFL

Spigot saddle with flange outlet, SDR 11

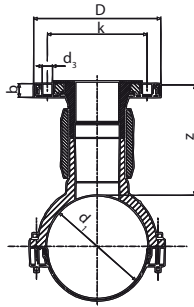

Spigot saddle with flange outlet SAFL SDR 11

- Gas and water
- Maximum pressure: Gas 10 bar; Water 16 bar
- Material; PE 100
- Saddle component with clamp and flange
- Possible tapping under pressure
- Safety technology
- DVGW test mark: DV-8606AU2249

Note:

For pressure-free tapping, we recommend our FWAB drilling device.

For tapping under pressure, we recommend the drilling tool from Hütz & Baumgarten (www.huetz-baumgarten.de).

Note the screw tightening torques after specifying the seal manufacturer and/or DVS and the utilisation of a GST seal.

If required, please contact our hotline: +49 621 486-2325.

PE 100 SDR 11

Maximum permissible working pressure 16 bar (water) / 10 bar (gas)



d ₁ /DN	Order No.	D	d _k	Drilling Ø d _a	H	L	Ø k	Holes for screws	Weight [kg]	BX	PU	Stock status
110/80	616016	204	16.50	65	296	190	160	8	3.700	3	54	1
125/80	616017	204	16.50	65	311	205	160	8	3.940	2	36	1
160/80	616018	204	16.50	65	346	245	160	8	4.320	2	36	1
180/80	616019	204	16.50	65	366	285	160	8	4.610	2	36	1
225/80	616020	204	16.50	65	411	284	160	8	4.720	2	16	1
160/100	616022	224	16.50	84	346	245	180	8	5.270	2	36	1
225/100	616024	224	16.50	84	411	284	180	8	5.635	2	16	1

SA TL

Top-loading spigot saddle, SDR 11

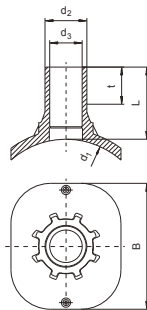

Top-loading spigot saddle SA TL SDR 11

- Gas, water and H₂
- Maximum pressure: Gas 10 bar; Water 16 bar
- Material; PE 100
- Universal clamping option (top loading):
 - Safe clamping with FRIATOP
 - Universal adaptation to pipe diameter
- Possible tapping under pressure
- Safety technology
- DVGW test mark: DV-8606AU2249 and DV-8611AU2250

Note:

Can only be used with the clamping device FRIATOP (Order No. 613350).

For pressure-free tapping, we recommend the drilling device from Hütz & Baumgarten (www.huetz-baumgarten.de).

For drilling under tapping, please contact our hotline: +49 621 486-2325.



PE 100 SDR 11

Maximum permissible working pressure 16 bar (water) / 10 bar (gas)



d ₁	d ₂	Order No.	d ₃	Drilling Ø d _a	L	Weight [kg]	BX	PU	Stock status
250-560	32	615465	21	20	109	0.621	5	90	1
250-560	63	615466	47	46	109	0.676	5	90	1



FRIALEN saddles

SA UNI

Saddle with outlet spigot Universal SDR 11

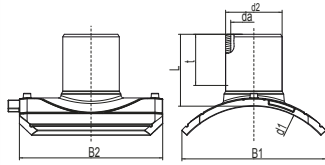

Saddle with outlet spigot Universal SA UNI SDR 11
Gas, water and H₂

- Maximum pressure: Gas 10 bar; Water 16 bar
- Material; PE 100
- Universal clamping option (balanced loading):
 - Safe clamping with UNITOP
 - Ideal distribution of force application
 - Perfect adaptation to pipe diameter
- Pressure test of the fusing before tapping possible
- Possible tapping under pressure
- Safety technology
- DVGW test mark: DV-8611AU2250



Note:

Can only be used with the clamping device UNITOP (Order No. 613385).
For pressure-free tapping, we recommend our FWAB drilling device.
Pressure test of the fusing before tapping with pressure test adapter FWDPA (Order No. 613596).
For tapping under pressure, please contact our hotline: +49 621 486-2325.
Also suitable for all special dimensions in relining application. For intermediate sizes in the diameter range $d_{280} < d_{315}$, please use SA UNI $d_{250} - 280$.



PE 100 SDR 11

Maximum permissible working pressure 16 bar (water) / 10 bar (gas)



d_1	d_2	Order No.	Drilling $\varnothing d_a$	L	Weight [kg]	BX	PU	Stock status
250-280	90	616553	65	130	1.465	5	40	1
250-280	110	616554	84	140	1.610	5	40	1
250-280	125	616555	95	146	1.790	5	40	1
250-280	160	616556	123	158	2.180	5	40	1
315-400	90	616557	65	130	1.485	5	40	1
315-400	110	616558	84	140	1.630	5	40	1
315-400	125	616559	95	146	1.810	5	40	1
315-400	160	616560	123	158	2.190	5	40	1
450-900	90	616561	65	130	1.500	5	40	1
450-900	110	616562	84	140	1.645	5	40	1
450-900	125	616563	95	146	1.820	5	40	1
450-900	160	616564	123	158	2.200	5	40	1



FRIALEN saddles

SA VL

Vacuum-loading spigot saddle, SDR 11

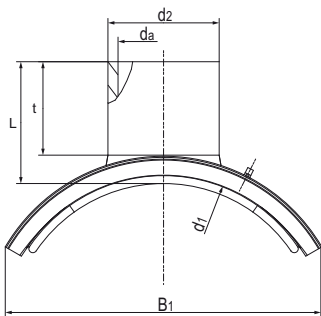

Vacuum-loading spigot saddle SA VL SDR 11 (and SDR 17)

- Gas, water and H₂
- Maximum pressure: Gas 10 bar; Water 16 bar
- Material; PE 100
- Vacuum clamping option (vacuum-loading):
 - Safe clamping with vacuum technology
 - Ideal contact with the pipe
 - Without wrapping around the pipe
- Possible tapping under pressure
- Safety technology

Note:

Can be used with the vacuum pump VACUPUMP only (Order No. 613827) and the corresponding plunger PRESSKO (Order No. 613823). For pressure-free tapping, we recommend our FWAB drilling device. For proper use and tapping under pressure, please contact our hotline: +49 621 486-2325.



PE 100 SDR 11

Maximum permissible working pressure 16 bar (water) / 10 bar (gas)



d ₁	d ₂	Order No.	Drilling Ø d _a	L	Weight [kg]	BX	PU	Stock status
400	225	616469	172	263	14.700	1	4	3
400	250	616779	187	261	15.200	1	4	3
450	225	616780	172	267	17.500	1	4	3
450	250	616781	187	272	18.000	1	4	3
500	225	616391	172	265	14.500	1	4	3
500	250	616782	187	263	15.500	1	4	3
500	280	616783	225	265	15.600	1	4	3
500	315	616784	254	268	21.600	1	4	3
560	225	616392	172	263	15.700	1	4	3
560	250	616785	187	263	17.000	1	4	3
560	280	616786	225	265	17.000	1	4	3
560	315	616787	254	268	19.800	1	4	3
560	355	616788	286	260	26.000	1	4	3
560	400	616789	322	260	27.200	1	4	3
630	225	616393	172	265	17.000	1	4	3
630	250	616790	187	267	17.500	1	4	3
630	280	616791	225	263	18.000	1	4	3
630	315	616792	254	265	20.900	1	4	3
630	355	616793	286	269	23.800	1	4	3
630	400	616794	322	267	25.000	1	4	3
710	225	616394	172	270	20.500	1	4	3
710	250	616795	187	265	22.100	1	4	3
710	280	616796	225	268	21.500	1	4	3
710	315	616797	254	268	23.800	1	4	3
710	355	616798	286	285	28.500	1	4	3
710	400	616762	322	275	29.500	1	4	3
800	225	616395	172	270	17.300	1	4	3
800	250	616799	187	275	18.600	1	4	3
800	280	616800	225	268	18.600	1	4	3
800	315	616801	254	268	20.500	1	4	3
800	355	616802	286	290	31.200	1	4	3
800	400	616803	322	275	31.600	1	4	3



FRIALEN saddles

SA VL Vacuum-loading spigot saddle, SDR 11

PE 100 SDR 11

Maximum permissible working pressure 16 bar (water) / 10 bar (gas)



d ₁	d ₂	Order No.	Drilling Ø d _a	L	Weight [kg]	BX	PU	Stock status
900	225	616396	172	268	19.000	1	4	3
900	250	616804	187	278	20.700	1	4	3
900	280	616805	225	268	20.300	1	4	3
900	315	616806	254	269	23.000	1	4	3
900	355	616807	286	305	27.300	1	4	3
900	400	616808	322	275	28.000	1	4	3
1000	225	616397	172	270	18.000	1	4	3
1000	250	616809	187	280	19.300	1	4	3
1000	280	616810	225	270	19.000	1	4	3
1000	315	616811	254	270	21.000	1	4	3
1000	355	616812	286	305	30.800	1	4	3
1000	400	616813	322	278	31.300	1	4	3
1200	225	616384	172	270	17.500	1	4	3
1200	250	616814	187	284	19.200	1	4	3
1200	280	616815	225	270	18.600	1	4	3
1200	315	616816	254	270	20.800	1	4	3
1200	355	616817	286	305	29.600	1	4	3
1200	400	616818	322	278	30.300	1	4	3

PE 100 SDR 17

Maximum permissible working pressure 10 bar (water) / 5 bar (gas)



d ₁	d ₂	Order No.	Drilling Ø d _a	L	Weight [kg]	BX	PU	Stock status
1000	160	616378	123	300	17.350	1	4	3
1200	160	616383	123	300	17.200	1	4	3



FRIALEN saddles

RS Repair Saddle, SDR 11

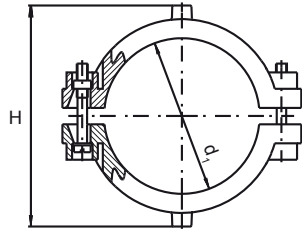

Repair saddle RS SDR 11

- Gas, water and H₂
- Maximum pressure: Gas 10 bar; Water 16 bar
- Material; PE 100
- Saddle component with clamp
- Safety technology

Note:

Only apply to minor pipe damage.
The damage must be located within the repair area and not in the fusion zone.

PE 100 SDR 11

Maximum permissible working pressure 16 bar (water) / 10 bar (gas)



d ₁	Order No.	H	Weight [kg]	BX	PU	Stock status
63	612519	106	0.260	20	360	1

RSV Repair and reinforcement saddle, SDR11

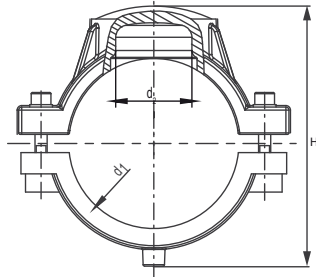

Repair and reinforcement saddle RSV SDR 11

- Gas, water and H₂
- Maximum pressure: Gas 10 bar; Water 16 bar
- Material; PE 100
- 2 combined saddle components
- Safety technology

Note:

Only apply to minor pipe damage.
The damage must be located within the repair area and not in the fusion zone.

PE 100 SDR 11

Maximum permissible working pressure 16 bar (water) / 10 bar (gas)



d ₁	d ₂	Order No.	H	Weight [kg]	BX	PU	Stock status
90	50	615164	148	0.920	24	192	1
110	50	615165	170	1.162	16	128	1
125	50	615166	183	1.360	15	120	1
160	50	615168	218	1.670	10	80	1
180	50	615169	238	1.810	6	48	1
200	50	615170	258	1.820	5	40	1
225	50	615171	283	1.900	5	40	1



FRIALEN saddles

RS TL

Repair saddle for top loading, SDR11

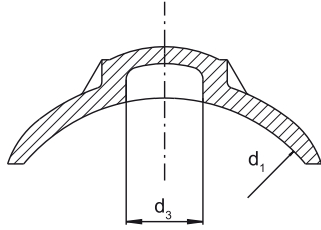

Repair saddle Top-Loading RS TL SDR 11

- Gas, water and H2
- Maximum pressure: Gas 10 bar; Water 16 bar
- Material; PE 100
- Universal clamping option (top loading):
 - Safe clamping with FRIATOP
 - Universal adaptation to pipe diameter
- Safety technology
- DVGW test mark: DV-8611AU2250

Note:

Can only be used with the clamping device FRIATOP (Order No. 616650).
 Only apply to minor pipe damage.
 The damage must be located within the repair area and not in the fusion zone.



PE 100 SDR 11

Maximum permissible working pressure 16 bar (water) / 10 bar (gas)



d ₁	Order No.	d ₃	Weight [kg]	BX	PU	Stock status
250-560	615397	50	0.570	10	180	1

FRIALEN®



FRIALEN saddles

RS VL

Vacuum-loading repair saddle SDR 11

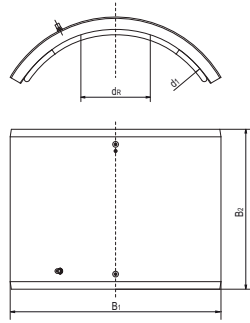

Vacuum-loading repair saddle RS VL SDR 11

- Gas, water and H₂
- Maximum pressure: Gas 10 bar; Water 16 bar
- Material; PE 100
- Vacuum clamping option (vacuum-loading):
 - Safe clamping with vacuum technology
 - Ideal contact with the pipe
 - Without wrapping around the pipe
- Safety technology

Note:

Can only be used with the vacuum pump VACUPUMP (Order No. 613827). Only apply to minor pipe damage. The damage must be located within the repair area and not in the fusion zone.



PE 100 SDR 17

Maximum permissible working pressure 10 bar (water) / 5 bar (gas)



d ₁	Order No.	Repair area d _R	Weight [kg]	BX	PU	Stock status
500	616366	230	13.600	1	4	3
560	616367	230	14.300	1	4	3
630	616368	230	15.000	1	4	3
710	616369	230	18.900	1	4	3
800	616370	230	15.800	1	4	3
900	616371	230	17.600	1	4	3
1000	616372	230	16.400	1	4	3
1200	616379	230	16.250	1	2	3

RW

Repair sleeve

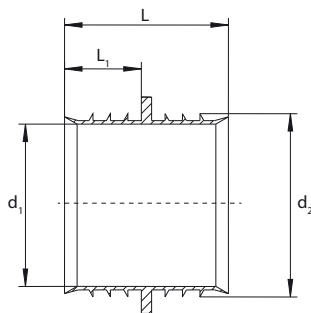
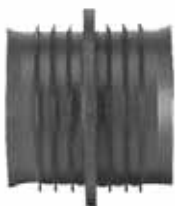

Repair sleeve RW

- For the repair of water-house connection pipes in a pressure-free condition.
- Prevents water from entering the fusion zone of the FRIALEN couplers MB or UB.

Note:

Dimension d means: Repair sleeve for pipe d xy.

Only suitable for pipe SDR 11

d	d ₁	d ₂	Order No.	L	L ₁	Weight [kg]	BX	PU	Stock status
32	21	27	615127	35	16	0.004	50	4500	1
40	28	34	615128	35	16	0.005	50	2500	1
50	36	42	615129	35	16	0.007	50	2500	1
63	46	53	615130	47	22	0.012	40	2000	1



FIXBLOC

Fixation for absorbing axial thrust and tensile forces

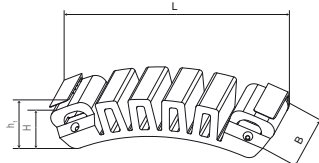

Fixation for absorbing axial thrust and tensile forces FIXBLOC

- For the production of a fixed point on a PE pipeline, as a pull-out fuse, installation aid or fixing to pipe supports
- Strength per fixed point up to 40 kN
- Multiple applications possible around the pipe circumference
- Processing is carried out with commercially available tensioning straps with a belt width of 50 mm, which are securely guided by two straps (easily removable)
- Minimum length approx. 3.5 x d pipe (longer for multiple applications)
- If the belt around the pipe circumference is not accessible, the clamping device FIXBLOC FWFB (Order No. 613380), e.g. in the case of a PE liner, which must be anchored relative to a shaft wall.



PE 100

Maximum shear load per FIXBLOC: 40 kN

d ₁	Order No.	H	L	Weight [kg]	BX	PU	Stock status
160 - 1600	680600	40	220	0.310	15	750	1

FRIALEN saddles

SPA Balloon shut off saddle

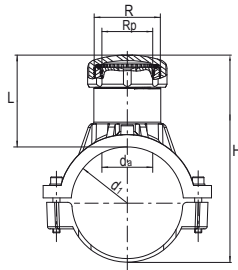

Balloon shut off saddle SPA

- Gas, water and H2
- Maximum pressure: Water 16 bar; Gas 10 bar
- Material; PE 100 and brass
- Saddle component with clamp
- Safety technology

Note:

Brass female and male threads are anchored in the HD-PE in a non-detachable and non-rotatable manner. Including brass plug with recessed square. For the accommodation of commercially available balloon setting devices.

Access protection for the dome by means of the supplied screw cap or by fusion on a FRIALEN SPAK (for d 63 by cap DK, Order No. 612310).

When using hydrogen, the SPA Balloon shut off saddle is only in conjunction with the cap SPAK (Order No. 612311).



PE 100 SDR 11

Maximum permissible working pressure 16 bar (water) / 10 bar (gas)



	d ₁	R	R _p	Order No.	Drilling Ø d _a	H	L	Weight [kg]	BX	PU	Stock status
1)	63	G 1 1/2	G 1 1/8	612753	31,0	151	80	0.610	20	360	1
	90	G 2 1/2	G 2	612677	56,5	197	104	1.380	16	128	1
	110	G 2 1/2	G 2	612750	56,5	217	104	1.540	12	96	1
	125	G 2 1/2	G 2	612751	56,5	232	104	1.710	12	96	1
	160	G 2 1/2	G 2	612752	56,5	267	104	1.860	8	64	1
	180	G 2 1/2	G 2	612754	56,5	287	104	1.860	7	56	1
	200	G 2 1/2	G 2	612755	56,5	307	104	1.830	6	48	1
	225	G 2 1/2	G 2	612756	56,5	332	104	1.850	5	40	1

1) SPA d 63 can only be fused with pipes of the SDR level 11.



FRIALEN saddles

SPA TL

Balloon shut off saddle top-loading

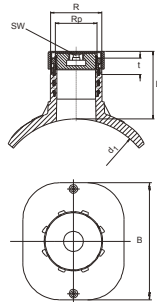

Balloon shut off saddle top-loading SPA TL

- Gas, water and H₂
- Maximum pressure: Water 16 bar; Gas 10 bar
- Material; PE 100 and brass
 - Universal clamping option (top loading):
 - Safe clamping with FRIATOP
- Safety technology

Note:

Can only be used with the clamping device FRIATOP (Order No. 616650). Brass female and male threads are anchored in the HD-PE in a non-detachable and non-rotatable manner.

Including brass plug with recessed square. For the accommodation of commercially available bubble setting devices.

Access protection for the dome by means of the supplied screw cap or by fusion on a FRIALEN SPAK.

When using hydrogen, the SPA balloon shut off saddle is only available in conjunction with the closure cap SPAK (Order No. 612311).



PE 100 SDR 11

Maximum permissible working pressure 16 bar (water) / 10 bar (gas)



d ₁	R	Rp	Order No.	Drilling Ø d _a	L	Weight [kg]	BX	PU	Stock status
250-355 (560)	G 2 1/2	G 2	615395	56,5	115	1.358	18	144	1

SPAK

Cap for balloon shut off saddles

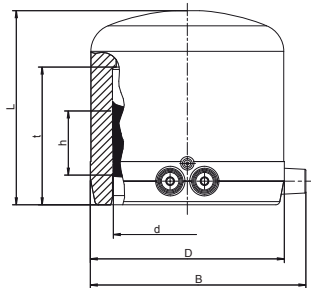

Cap for balloon shut off saddles SPAK

With open-wire technology for optimal heat transfer, large insertion depths, wide fusion zone and cold zone preventing the flow of melt.

When using hydrogen, the cap SPAK with the balloon shut off saddle SPA must be used.

PE 100 SDR 11

Maximum permissible working pressure 16 bar (water) / 10 bar (gas)



d	Order No.	D	L	Weight [kg]	BX	PU	Stock status
75	612311	99	99	0.280	20	640	1



VAM RG

Valve tapping saddle with transition HD-PE/gunmetal

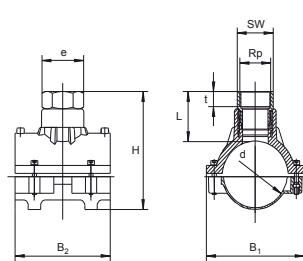

Valve tapping saddle with transition HD-PE/gunmetal VAM RG

- Gas, water
- Maximum pressure: Water 16 bar; Gas 10 bar
- Material; PE 100 and gunmetal (female thread)
- Saddle component with clamp
- Safety technology
- Metals in contact with water according to UBA recommendation

Note:

For accommodating commercially available brass valves.
As a complete solution, we recommend our DAV tapping valve.

PE 100 SDR 11

Maximum permissible working pressure 16 bar (water) / 10 bar (gas)



	d	Rp	Order No.	H	L	Weight [kg]	BX	PU	Stock status
1)	63	1 1/4"	612794	146	75	0.730	20	360	3
	63	1 1/2"	612743	149	78	0.780	20	360	1
	75	1 1/4"	615213	161	76	0.850	15	270	1
	90	1 1/2"	612798	172	68	1.370	16	128	1
1)	90	2"	612778	199	95	1.560	16	128	3
	110	1 1/2"	612732	182	70	1.488	12	96	1
	110	2"	612733	205	92	1.684	12	96	1
1)	125	1 1/2"	612734	207	68	1.610	12	96	3
	125	2"	612735	234	95	1.850	12	96	1
1)	160	1 1/2"	612728	242	68	1.800	8	64	3
	160	2"	612729	269	95	2.040	8	64	1
1)	180	1 1/2"	612774	250	68	1.780	7	56	1
	180	2"	612776	277	95	1.990	7	56	1
	225	2"	612827	322	95	1.990	5	40	1

1) Minimum purchase quantity is a packaging unit (BX).

VAM RG TL

Valve tapping saddle top-loading with HD-PE/Gunmetal adapter

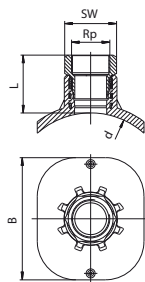

Valve tapping saddle with HD-PE/Gunmetal adapter VAM RG TL

- Gas, water
- Maximum pressure: Water 16 bar; Gas 10 bar
- Material; PE 100 and gunmetal (female thread)
 - Universal clamping option (top loading):
 - Safe clamping with FRIATOP
- Safety technology
- Metals in contact with water according to UBA (Federal Environment Agency, Germany) recommendation

Note:

Can only be used with the clamping device FRIATOP (Order No. 616650).
For accommodating commercially available brass valves.
Dimension range d 250 - d 560 can be fused as standard in the top loading process.
As a complete solution, we recommend our DAV tapping valve.



PE 100 SDR 11

Maximum permissible working pressure 16 bar (water) / 10 bar (gas)



	d	Rp	Order No.	L	Weight [kg]	BX	PU	Stock status
	250 - 560	2"	615470	90	1.505	8	144	1



FRIALEN transition fittings

USTR Transition fitting, steel pipe

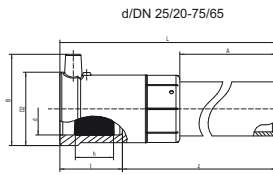

Transition fitting, steel pipe USTR

- Gas and H₂
- Maximum pressure: Gas 10 bar
- Material; PE 100 and steel [EN 10220 / EN 10216-1 - P235TR2]
- Safety technology

Note:

Anchored the steel side non-detachable and non-rotatable in the PE.
 Self-sealing, patented sealing geometry without elastomeric gasket for use in gas applications.
 Steel pipe batch characterised by re-stamping of the pipe connection.



PE 100 SDR 11

Maximum permissible working pressure 10 bar (gas)

	d/DN	Order No.	D ₁	L	Weight [kg]	BX	PU	Stock status
1)	32/25	612780	34	387	0.820	15	360	1
1)	40/32	612781	42	393	1.070	10	240	1
1)	50/40	612782	48	409	1.320	8	192	1
1)	63/50	612783	60	410	1.880	6	144	1
	75/65	612789	76	425	4.420	4	96	1
1)	90/80	612784	89	405	5.350	1	77	1
1)	110/100	612785	114	420	8.380	1	54	1
1)	125/100	612786	114	425	8.870	1	45	1
	160/150	612787	168	484	17.000	1	24	1
	180/150	615030	171	500	21.250	1	18	1
	200/200	612795	219	480	27.020	1	12	1
	225/200	612370	219	505	27.350	1	11	1

1) Pipe seamless, welded ends according to standard: DIN EN 10220/EN 10216-1, ASTM A106/A106M-14



FRIALEN transition fittings

USTRS

Transition fitting, steel pipe, spigot

Transition fitting for steel pipe, spigot USTRS

- Gas
- Maximum pressure: Gas 10 bar
- Material; PE 100 and steel [ISO 3183 / API5L]



Note:

To be utilised with the fusion couplers UB.

Anchored the steel side non-detachable and non-rotatable in the PE.

Steel pipe batch characterised by re-stamping of the pipe connection.

PE 100 SDR 11

Maximum permissible working pressure 10 bar (gas)



d/DN	Order No.	D	L	L ₁	w	Weight [kg]	BX	PU	Stock status
20/15	616632	45	425	80	2,60	0.450	21	630	3
25/20	616633	45	460	90	2,60	0.650	21	630	1
32/25	616634	51	460	95	3,20	0.950	18	540	1
40/32	616635	63	470	100	3,20	1.250	12	360	3
50/40	616636	70	480	110	3,20	1.450	8	240	1
63/50	616637	89	480	110	3,60	2.150	6	216	1
75/65	616638	95	540	130	3,60	2.950	2	98	3
90/80	616639	117	580	140	4,00	3.950	2	98	1
110/100	616640	150	585	145	5,40	7.050	2	50	1
125/100	616641	150	585	150	5,40	7.300	2	50	1
140/125	616642	163	580	155	5,00	8.000	1	25	3
160/150	616643	210	610	160	5,00	10.500	1	25	1
180/150	616644	210	610	170	5,00	11.000	1	25	1
200/200	616645	259	630	155	6,30	17.500	1	16	1
225/200	616646	259	610	145	6,30	18.000	1	16	1
250/250	616647	324	640	140	6,30	30.500	1	8	3
280/250	616648	324	640	160	6,30	31.000	1	8	3
315/300	616649	368	725	220	8,80	46.500	1	6	1
355/300	616650	368	735	260	8,80	48.000	1	6	3
400/400	616651	475	770	190	8,80	83.200	1	3	3
500/500	616652	590	1050	365	10,00	127.500	1	2	3
630/600	616653	735	1100	430	12,70	242.000	1	2	3

UFLG

Transition fitting HD-PE/copper (spigot fitting)

Transition fitting as copper pipe UFLG

- Gas
- Maximum pressure: Gas 5 bar
- Material; PE 100 and copper [SF Cu-F25, DIN EN 1057-R250]
- Safety technology

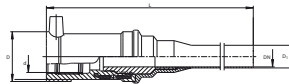

Note:

Secure the copper side in the PE.

Self-sealing, patented sealing geometry without elastomeric gasket for use in gas applications.

PE 100 SDR 11

Maximum permissible working pressure 5 bar (gas)



d/DN	Order No.	D	D ₁	L	Weight [kg]	BX	PU	Stock status
32/20	615733	49	22	340	0.510	25	750	1



FRIALEN transition fittings

USTN

Transition fitting HD-PE/steel with male thread

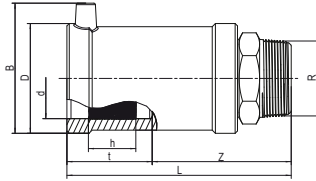

Transition fitting, steel pipe USTN

- Gas and H₂
- Maximum pressure: Gas 5 bar
- Material; PE 100 and steel [EN 10278; EN 10277-3 - 11SMn30+C -, thread to EN 10226-1]
- Safety technology

Note:

Anchored the steel side non-detachable and non-rotatable in the PE.
Self-sealing, patented sealing geometry without elastomeric gasket for use in gas applications.
Other thread dimensions available on request.



PE 100 SDR 11

Maximum permissible working pressure 5 bar (gas)

d	R	Order No.	D	L	Weight [kg]	BX	PU	Stock status
32	1"	612580	47	119	0.345	20	1080	1
40	1 1/4"	612582	58	131	0.530	20	800	1
50	1 1/2"	612584	70	146	0.700	15	600	1
63	2"	612586	84	152	1.050	10	400	1

USTM

Transition fitting HD-PE/steel with female thread

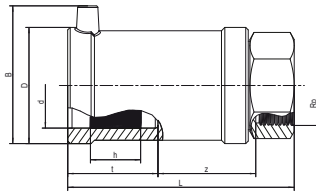

Transition fitting steel pipe USTM

- Gas and H₂
- Maximum pressure: Gas 5 bar
- Material; PE 100 and steel [EN 10278; EN 10277-3 - 11SMn30+C -, thread to EN 10226-1]
- Safety technology

Note:

Anchored the steel side non-detachable and non-rotatable in the PE.
Self-sealing, patented sealing geometry without elastomeric gasket for use in gas applications.
Other thread dimensions available on request.



PE 100 SDR 11

Maximum permissible working pressure 5 bar (gas)

d	Rp	Order No.	D	L	Weight [kg]	BX	PU	Stock status
32	1"	612570	47	112	0.340	20	1080	1
40	1 1/4"	612572	58	121	0.500	20	800	1
50	1 1/2"	612574	70	136	0.650	15	600	1
63	2"	612576	84	141	1.010	10	400	1



FRIALEN transition fittings

MUN

Transition fitting in HD-PE/brass with male thread

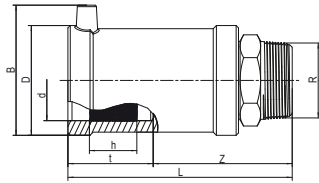

Brass pipe transition fitting MUN

- Water
- Maximum pressure: Water 16 bar
- Material; PE 100 and brass [EN 12168 - CW617N, thread according to EN 10226-1]
- Safety technology

Note:

The brass side is anchored as non-detachable and non-rotatable in PE. Self-sealing, patented sealing geometry without elastomeric seal for utilisation in water areas.

Default: Brass, gunmetal on request.

Other thread dimensions available on request.

PE 100 SDR 11

Maximum permissible working pressure 16 bar (water)



d	R	Order No.	D	L	Weight [kg]	BX	PU	Stock status
32	1"	612712	47	112	0.310	20	1440	1
32	1 1/4"	612709	47	120	0.390	20	1080	1
32	1 1/2"	612698	47	121	0.450	15	810	1
40	1"	612721	58	123	0.480	20	800	1
40	1 1/4"	612713	58	126	0.460	20	800	1
40	1 1/2"	612718	58	127	0.520	20	800	1
40	2"	612725	58	132	0.680	20	600	1
50	1"	612719	70	134	0.620	15	600	1
50	1 1/4"	612716	70	136	0.610	15	600	1
50	1 1/2"	612714	70	137	0.620	15	600	1
50	2"	612706	70	147	0.760	15	600	1
63	1 1/4"	612722	84	138	0.910	10	400	1
63	1 1/2"	612717	84	137	0.890	10	400	1
63	2"	612715	84	142	0.920	10	400	1
75	2"	612694	98	165	1.470	10	240	1
75	2 1/2"	612695	98	167	1.490	10	240	1

MUN V2A

Transition fitting HD-PE/V2A with male thread

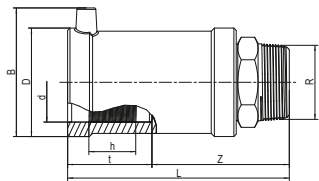

Transition fitting V2A pipe MUN V2A

- Water
- Maximum pressure: Water 16 bar
- Material; PE 100 and V2A [EN 10278 ; EN 10088-3 - 1.4305 -X8CrNiS18-9, thread according to EN 10226-1]
- Safety technology

Note:

V2A side is anchored in the PE so that it cannot be rotated.

Self-sealing, patented sealing geometry without elastomeric seal for utilisation in water areas.

Other thread dimensions available on request.

PE 100 SDR 11

Maximum permissible working pressure 16 bar (water)



d	R	Order No.	D	L	Weight [kg]	BX	PU	Stock status	
1)	40	1"	616516	58	123	0.460	20	800	3
	40	1 1/2"	612727	58	127	0.495	20	800	1
	50	1 1/2"	612726	70	137	0.600	15	600	1
	63	1 1/2"	612705	84	137	0.865	10	400	1
	63	2"	612899	84	142	0.910	10	400	1

1) Minimum purchase quantity is a packaging unit (BX).



FRIALEN transition fittings

MUM

Transition fitting HD-PE/gunmetal with female thread

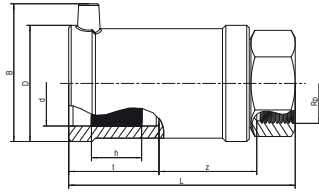

Transition fitting gunmetal pipe MUM

- Water
- Maximum pressure: Water 16 bar
- Material; PE 100 and gunmetal [EN 1982 - CC499K-GC, thread to EN 10226-1]
- Safety technology

Note:

Gunmetal side is anchored non-detachable and non-rotatable in the PE. Self-sealing, patented sealing geometry without elastomeric seal for utilisation in water areas.

Default: Gunmetal, V2A on request.

Other thread dimensions available on request.

PE 100 SDR 11

Maximum permissible working pressure 16 bar (water)



d	Rp	Order No.	D	L	Weight [kg]	BX	PU	Stock status
32	1"	612595	47	112	0.360	20	1080	1
40	1 1/4"	612596	58	121	0.520	20	800	1
50	1 1/2"	612692	70	136	0.650	15	600	1
63	1 1/2"	612708	84	141	1.230	10	300	1
63	2"	612693	84	141	1.050	10	400	1

UAM ET

Universal transition adaptor HD-PE/brass with free union nut with female thread

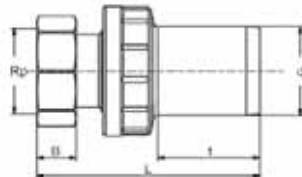

Universal transition adaptor brass pipe UAM ET

- Water
- Maximum pressure: Water 16 bar
- Material; PE 100 and brass [CW617N or CW612N, ISO 228 thread]

Note:

The brass side is anchored non-detachable and non-rotatable in the PE. With freely rotatable union nut for easy and fast assembly.

For use in water areas.

Other thread dimensions available on request.

PE 100 SDR 11

Maximum permissible working pressure 16 bar (water)



d	Rp	Order No.	L	t	Weight [kg]	BX	PU	Stock status
25	3/4"	616654	110	44	0.160	60	2160	1
32	1"	616655	120	47	0.330	30	1080	1
40	1 1/4"	616626	145	56	0.520	20	720	1
50	1 1/2"	616627	150	57	0.650	16	576	3
63	1 1/2"	616629	160	63	0.740	9	324	1
63	2"	616628	170	63	0.920	9	324	3



FRIALEN transition fittings

WUN 90

90° transition elbow HD-PE/brass with external thread

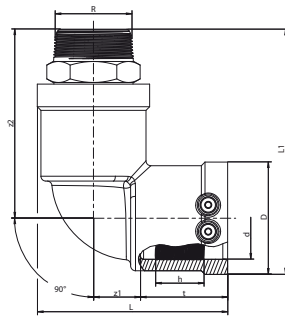

Transition elbow brass pipe WUN 90

- Water
- Maximum pressure: Water 16 bar
- Material; PE 100 and brass [EN 12168 - CW617N, thread according to EN 10226-1]
- Safety technology

Note:

The brass side is anchored as non-detachable and non-rotatable in PE. Self-sealing, patented sealing geometry without elastomeric seal for utilisation in water areas.

Default: Brass, gunmetal on request.

Other thread dimensions available on request.

PE 100 SDR 11

Maximum permissible working pressure 16 bar (water)



d	R	Order No.	D	L	Weight [kg]	BX	PU	Stock status
32	1"	612120	47	85	0.340	20	1000	1
32	1 1/2"	612140	47	94	0.470	20	800	1
40	1"	612127	58	102	0.500	15	750	1
40	1 1/4"	612122	58	102	0.520	15	750	1
40	1 1/2"	612121	58	102	0.560	15	750	1
50	1"	612119	70	118	0.680	10	500	1
50	1 1/4"	612123	70	118	0.670	10	500	1
50	1 1/2"	612124	70	118	0.680	10	500	1
63	1 1/2"	612125	84	128	0.980	10	320	1
63	2"	612126	84	128	1.000	10	320	1

WUN V2A 90

Transition elbow 90° HD-PE/Stainless steel with male thread

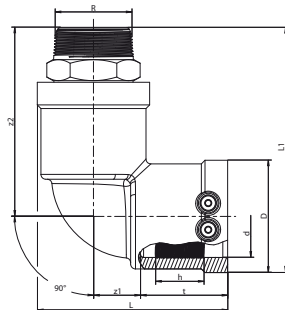

Transition elbow 2VA pipe WUN V2A 90

- Water
- Maximum pressure: Water 16 bar
- Material; PE 100 and 2VA [EN 10278 ; EN 10088-3 - 1.4305 -X8CrNiS18-9, thread according to EN 10226-1]
- Safety technology

Note:

V2A side is anchored in the PE so that it cannot be rotated.

Self-sealing, patented sealing geometry without elastomeric seal for utilisation in water areas.

Other thread dimensions available on request.

PE 100 SDR 11

Maximum permissible working pressure 16 bar (water)



d	R	Order No.	D	L	Weight [kg]	BX	PU	Stock status
40	1"	616514	58	102	0.540	15	750	1
40	1 1/2"	612148	58	102	0.535	15	750	1
50	1 1/2"	612118	70	118	0.650	10	600	1
63	1 1/2"	612186	84	128	0.980	10	320	1
1)	63	2"	616515	84	0.950	10	320	3

1) Minimum purchase quantity is a packaging unit (BX).



FRIALEN transition fittings

UAN

Universal adaptor HD-PE/brass with male thread and PE pipe socket

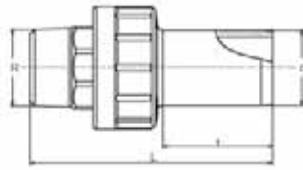

Universal transition adaptor brass pipe UAN

- Water and gas
- Maximum pressure: Water 16 bar, gas 5 bar
- Material; PE 100 and brass [CW617N / CW612N, ISO 228 thread]

Note:

The brass side is anchored non-detachable and non-rotatable in the PE.
Installation independent of position possible.
For use in the water and gas sector.
Other thread dimensions available on request.

PE 100 SDR 11

Maximum permissible working pressure 16 bar (water) / 5 bar (gas)



d	R	Order No.	L	t	Weight [kg]	BX	PU	Stock status
20	1/2"	616604	94	41	0.100	70	4200	1
25	3/4"	616605	92	44	0.150	60	3600	1
32	1"	616152	104	47	0.240	30	1800	1
40	1 1/4"	616153	121	56	0.400	20	1200	1
50	1 1/2"	616154	123	57	0.520	16	960	1
63	1 1/2"	616610	136	63	0.620	9	540	1
63	2"	616155	140	63	0.730	9	540	1
75	2 1/2"	616612	155	70	1.200	10	300	1
90	3"	616613	172	78	1.600	8	240	1
110	4"	616614	200	87	2.900	4	120	3
125	4"	616664	200	92	2.950	4	120	3

UAM

Universal transition adaptor HD-PE/brass with female thread

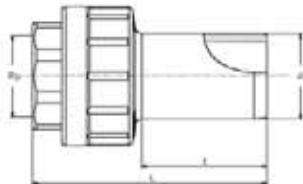

Universal transition adaptor brass pipe UAM

- Water and gas
- Maximum pressure: Water 16 bar, gas 5 bar
- Material; PE 100 and brass [CW617N / CW612N, ISO 228 thread]

Note:

The brass side is anchored non-detachable and non-rotatable in the PE.
Installation independent of position possible.
For use in the water and gas sector.
Other thread dimensions available on request.

PE 100 SDR 11

Maximum permissible working pressure 16 bar (water) / 5 bar (gas)



d	Rp	Order No.	L	t	Weight [kg]	BX	PU	Stock status
20	1/2"	616615	79	41	0.080	80	4800	1
25	3/4"	616616	77	44	0.120	60	3600	1
32	1"	616156	88	47	0.190	36	2160	1
40	1 1/4"	616157	100	56	0.290	20	1200	1
50	1 1/2"	616158	102	57	0.350	16	960	1
63	1 1/2"	616621	115	63	0.450	10	600	1
63	2"	616159	120	63	0.580	10	600	1
75	2 1/2"	616665	128	70	0.760	10	300	1
90	3"	616623	144	78	1.030	8	240	1
110	4"	616624	161	87	1.870	6	180	3
125	4"	616666	161	92	1.990	6	180	3



FRIALEN transition fittings

EFL

Full faced flange (spigot fitting)

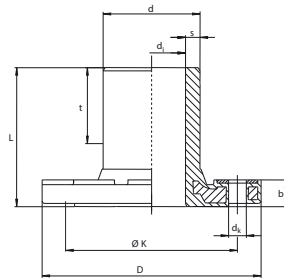

Flange adapter and flange EFL

- Water and gas
- Maximum pressure: Water 16 bar, gas 10 bar
- Material; PE 100 and metal insert

Note:

Metal insert in flange in order to prevent cold flow.
 Fused side for processing with FRIALEN couplers MB or UB.
 We recommend GST seals.
 Note the screw tightening torques after specifying the seal manufacturer or DVS.
 Additional washers are required.

PE 100 SDR 11

Maximum permissible working pressure 16 bar (water) / 10 bar (gas)



d/DN	Order No.	D	d _i	d _k	L	s	Ø k	Holes for screws	Weight [kg]	BX	PU	Stock status
63/50	615417	169	51	17.00	105	5,8	125	4	1.500	5	250	1
90/80	615418	204	72	17.00	130	8,2	160	8	2.540	5	160	1
110/100	615419	224	87	17.00	150	10,0	180	8	3.310	3	96	1
125/100	615605	224	101	17.00	160	11,4	180	8	3.280	2	64	1
160/150	615421	288	127	21.00	190	14,6	240	8	6.140	2	36	1
180/150	615927	288	123	21.00	200	16,4	240	8	6.660	2	36	1
1) 225/200	615607	343	180	21.00	225	20,4	295	8	9.100	1	27	1

1) Flange drill hole for PN 10

FLR

Flange reducer

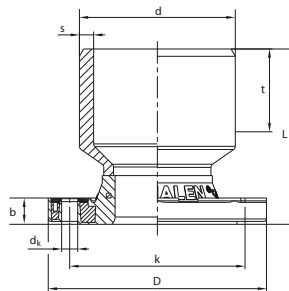

FLR flange reduction

- Water
- Maximum pressure: Water 16 bar
- Material; PE 100 and metal insert

Note:

Metal insert in flange in order to prevent cold flow.
 We recommend GST seals.
 Note the screw tightening torques after specifying the seal manufacturer or DVS.
 Additional washers are required.

PE 100 SDR 11

Maximum permissible working pressure 16 bar (water)



d/DN	Order No.	D	d _k	L	s	Ø k	Holes for screws	Weight [kg]	BX	PU	Stock status
110/80	616065	204	17.00	161	10	160	8	3.500	3	96	1
160/100	616241	224	17.00	180	14,6	180	8	4.060	2	64	1





FRIAFIT[®] sewage system

The closed PE system for sewage, wastewater, storm and grey water pipe systems.

Product range AF 26/22

Things worth knowing about FRIAFIT® Sewage System and this Product Range

Component traceability

Each component is equipped with an additional barcode for component traceability.

Norm Conformity

The FRIAFIT sewage system made of PE 100 complies with EN 12666 and is therefore regarded as a regulated construction product. Therefore, there is no need for a general building supervision approval. A certificate of conformity from the DIBt®, Berlin, is available.

The FRIAFIT spigot ASA MULTI is generally approved under construction regulations. You can find the registration notice in the download area on our homepage.

FRIAFIT couplers AM SDR 17 also fulfil the requirements of EN 12201 and ISO 4427.

FRIAFIT couplers AM SDR 17 are certified according to DVGW GW 335-B2 with the certificates DV-8606BO6114 and DV-8611BO6115 and are subjected to regular external monitoring.

The scope of the respective certifications of individual products is based on applicability and market requirements. Please inspect for individual cases whether the required certification is available for the respective product.



Fusability

FRIAFIT safety fittings can be fused with SDR levels 33 to 17. Other levels of SDR can be processed on request.

Please also note the details of the respective fusion-capable SDR levels, which are indicated on the bar code label of the fitting and further binding labels directly on the product.

Please contact our application technology when you want to process thin-walled pipes > SDR33.

FRIAFIT safety fittings can be processed with pipes made of PE 100 and PE 100-RC, PE 80 according to EN 12666, DIN 8074/75, EN 1555-2, EN 12201-2, ISO 4437 and ISO 4427, PE-Xa according to DIN 16892/93. For PE pipes, a melt flow rate of MFR 190/5 in the range from 0.2 to 1.7 g/10 minutes applies. For components with MFR < 0.20, a confirmation of suitability is required.

Processing the FRIAFIT safety fittings is possible with FRIAMAT fusion units at ambient temperatures between -10 °C and +45 °C.

In the case of material transfer joints, the material-specific standards or system-specific standards and assembly guidelines also apply.

Please read our assembly instructions for any restrictions regarding installation, laying as well as processing of FRIAFIT safety fittings in general. Our customer service department and our field application technicians will also be pleased to answer any questions.

Pressure bearing capacity

The FRIAFIT sewage system is designed for pressure-free pipes. According to DIN EN 1610, the test pressure is maximum 0.5 bar.

FRIAFIT couplers AM SDR 17 are also approved for use in drinking water and pressure pipe systems PN10.

FRIAFIT sewage bends ABM/ABMS and the sewage saddles ASA TL, ASA UNI and ASA VL are designed for pressure pipe systems with a permanent working pressure of maximum 2.5 bar.

Information regarding the pressure bearing capacity can be found in the respective product description.

Fusion process

FRIAFIT safety fittings can be processed with universal fusion units, e.g. the FRIAMAT series. The fusion parameters are automatically transmitted by the fitting barcode.

Cooling times

FRIAFIT couplers, sewage insert sleeves, drainage bends, transition couplers and FIXBLOC:
The cooling times (CT) indicated on the bar codes are understood as times until the movement of the welded connection.

FRIAFIT sewage saddles ASA TL, ASA UNI and ASA VL and transition saddle ASA TL KG:
The cooling time indicated on the bar code of the saddle is understood as the time until drilling.

For further details, please refer to our assembly instructions.

Processing instructions and additional information

The processing takes place according to our assembly instructions, which are also available for download on the Internet at www.aliaxis.de. You can also find further information about the products and their processing, approvals, publications as well as seminar dates and contact persons via the navigation.

Statics

The structural calculations for of the HD-PE channel pipe must be executed in each individual case by the respective pipe manufacturer or engineering office, depending on the ambient conditions.

The annular stiffness of the pipe connection, which is fused with FRIAFIT couplers, is in any case higher than the annular stiffness of the pipe inserted.



Safety Technology

Open wire design



Our unique technology and design delivers the **IDEAL SOLUTION** for safe electrofusion connections.

Large insertion depth & longer fusion zones



The ideal embedding of exposed heating coils guarantees the fast and safe assembly of our safety fittings.



Large insertion depth and longer fusion zones ensures an unrivaled safe and secure jointing process.



AM

Coupler without inner stop, SDR 17

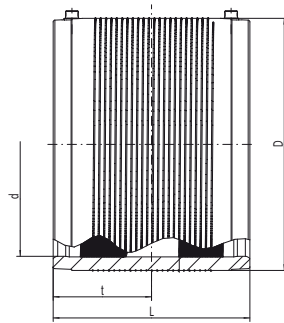

Coupler without inner stop, SDR 17

- For connecting water and sewage pipes made from HD-PE
- Safety technology
- For processing without holding devices
- With pin indicator for visual inspection of the fusion

PE 100 SDR 17

Maximum permissible working pressure 10 bar (water / sewage)

d	Order No.	D	L	t	Weight [kg]	BX	PU	Stock status
110	680001	130	160	80	0.600	24	192	1
125	680013	146	160	80	0.650	22	176	1
160	680002	184	180	90	1.100	12	96	1
180	680003	207	180	90	1.450	8	64	1
200	680004	236	180	90	2.070	1	75	1
225	680005	263	200	100	2.723	1	52	1
250	680006	282	220	110	2.200	1	44	1
280	680007	316	220	110	3.800	1	32	1
315	680008	355	220	110	4.750	1	24	1
355	680009	400	220	110	5.900	1	24	1
400	680010	450	220	110	7.300	1	12	1
450	680011	506	270	135	11.200	1	6	1
1)	500	680012	562	270	14.450	1	4	1
1) 2)	560	680018	630	380	24.350	1	2	1
1) 2)	630	680019	710	420	35.000	1	2	1

1) separate fusion zones

2) with pre-heating technology for optimum gap bridging

For use with close-fit liners, please contact our hotline +49 621 486-1896.

UB SDR 17

Coupler without inner stop, SDR 17

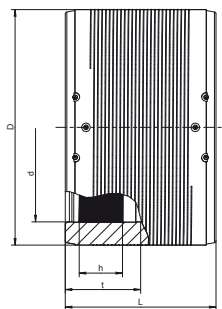

Coupler UB SDR 17 without inner stop

- Gas and water
- Maximum pressure: Gas 5 bar; Water 10 bar
- Material; PE 100
- Safety technology
- Separate fusion zone
- DVGW test mark: DV-8611AU2250 and DW-8610CN0420

Note

From nominal size 560 with preheating technology and from nominal size 1000, only one FRIAMAT XL is to be utilised, which is available as a loan device under Order No. 613091.

PE 100 SDR 17

Maximum permissible working pressure 10 bar (water / sewage)

d	Order No.	D	L	B	t	Weight [kg]	BX	PU	Stock status
710	615994	800	442	802	221	46.000	1	2	1
800	616290	900	500	902	250	65.900	1	1	1
900	616345	1024	500	1026	250	91.500	1	1	1
1000	616403	1130	610	1132	305	128.000	1	1	3
1200	616416	1356	670	1358	335	205.000	1	1	3



REM SDR 17 Reducer, SDR 17 for Relining

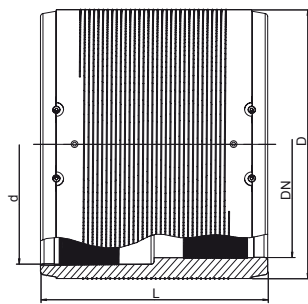

Reducer REM, SDR 17 for Relining

- Gas and water
- Maximum pressure: Gas 5 bar; Water 10 bar
- Material; PE 100
- Problem solver for pipe refurbishment work (relining)
- Safety technology
- Separate fusion zone
- Preheating technology

PE 100 SDR 17

Maximum permissible working pressure 10 bar (water / sewage)

d/DN	Order No.	D	h1	L	B	t	Weight [kg]	BX	PU	Stock status
110/100	615569	130	30	160	144	80	0.700	24	192	1
160/150	615571	190	38	180	199	90	1.600	12	96	1
315/300	615576	355	78	300	355	150	7.700	1	18	1

ASF

Shaft lining adapter for prefabricated concrete sewage inspection chambers

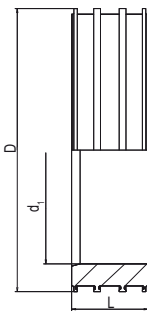

Shaft lining adapter for prefabricated concrete sewage inspection chambers ASF

- Connecting element between concrete prefabricated manhole and sewage-insert sleeve AEM
- Reversed anchoring webs (T-section) on the entire circumferential width always ensure a firm and tight fit in the concrete
- Defined internal surface and fitting ratio for reliable system seal with AEM
- Stable internal diameter due to large wall thickness
- Flush closure (inside and outside) in the concrete shaft sub-section according to DIN 4034

PE 100

Maximum permissible test pressure 0.5 bar to DIN EN 1610

Ø Pipe	d ₁	Order No.	D	L	Weight [kg]	BX	PU	Stock status
110	134	680401	200	135	1.600	12	96	1
160	190	680402	250	135	1.900	8	64	1
180	218	680403	280	135	2.300	6	48	1
200	250	680404	315	135	2.700	4	32	1
225	280	680405	355	135	3.700	4	32	1
250	316	680407	400	135	4.800	4	32	1
280	357	680408	450	135	6.200	1	18	1
315	402	680409	500	135	7.400	1	18	1
355	452	680410	560	135	9.300	1	12	1
400	502	680411	630	135	12.700	3	6	1
450	562	680414	670	135	11.300	3	6	1
500	628	680412	710	135	8.800	3	6	1
560	713	680413	800	135	10.700	3	6	1

Note: If pipe dimensions ≥ d 710 are used, please contact our hotline +49 621 486-1896.



ASFL

Shaft lining adapter for sewage inspection chambers L = 250 mm

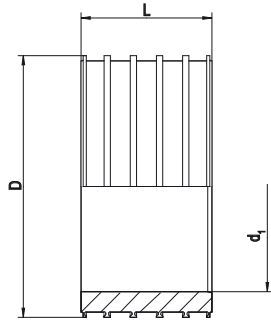

Shaft lining adapter for sewage inspection chambers L = 250 mm ASFL

- Connecting element between a brick shaft or concrete shaft and FRIAFIT sewage insert sleeve AEM for installation on the construction site
- Reversed anchoring webs (T-section) on the entire circumferential width ensure a firm and tight fit in the shaft
- Defined internal surface and fitting ratio for reliable system seal with AEM
- Stable internal diameter due to large wall thickness

PE 100

Maximum permissible test pressure 0.5 bar to DIN EN 1610

Ø Pipe	d ₁	Order No.	D	L	Weight [kg]	BX	PU	Stock status
225	280	680505	355	250	4.670	2	16	1
250	316	680507	400	250	6.650	2	16	1
280	357	680508	450	250	8.750	1	9	1
315	402	680509	500	250	11.050	1	6	1
355	502	680511	630	250	23.400	1	2	1
450	628	680512	710	250	16.400	1	2	1
560	713	680513	800	250	20.300	1	2	1

Note: If pipe dimensions ≥ d 710 are used, please contact our hotline +49 621 486-1896.

AEM

Plug-in coupler for shaft lining adapter

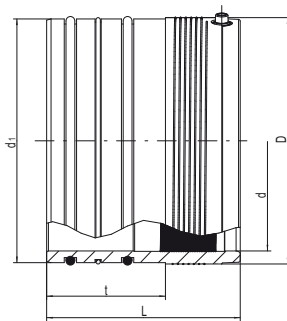

Plug-in coupler for shaft lining adapter AEM

- For the articulated connection of HD-PE pipes into ducts in accordance with DIN 4034 or DWA-A 157 together with the FRIAFIT adapter ASF/ ASFL
- With two elastomeric sealing rings as hinge for optimum compression
- With water-swellaable sealing ring Q for additional safety
- Connection side to HD-PE pipe with open-wire technology for optimal heat transfer for use without holding devices
- Safety technology
- Level transition to chamber sole

Note:

Also available with NBR seals: Stocked Status 3

PE 100

Maximum permissible test pressure 0.5 bar to DIN EN 1610

d	d ₁	Order No.	D	L	t	Weight [kg]	BX	PU	Stock status
110	131	680201	133	165	135	0.700	8	144	1
160	187	680202	193	225	135	1.900	8	64	1
180	215	680203	225	220	135	3.100	1	54	1
200	247	680204	250	220	135	3.500	1	56	1
225	277	680205	280	220	135	4.600	1	32	1
250	277	680206	280	220	135	2.500	1	32	1
280	313	680207	315	220	135	3.600	1	32	1
315	354	680208	355	220	135	4.350	1	24	1
355	399	680209	400	220	135	5.800	1	20	1
400	449	680210	450	220	135	8.300	1	12	1
450	499	680211	500	220	135	8.900	1	8	1
500	559	680214	562	220	135	11.050	1	8	1
1) 560	624	680212	630	220	135	13.400	1	4	1
1) 630	709	680213	710	270	135	22.400	1	3	1

1) with pre-heating technology for optimum gap bridging



FIXBLOC

Fixation for absorbing axial thrust and tensile forces

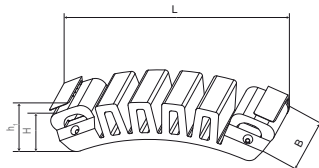

Fixation for absorbing axial thrust and tensile forces FIXBLOC

- For the production of a fixed point on a PE pipeline, as a pull-out fuse, installation aid or fixing to pipe supports
- Strength per fixed point up to 40 kN
- Multiple applications possible around the pipe circumference
- Processing is carried out with commercially available tensioning straps with a belt width of 50 mm, which are securely guided by two straps (easily removable)
- Minimum length approx. 3.5 x d pipe (longer for multiple applications)
- If the belt around the pipe circumference is not accessible, the clamping device FIXBLOC FWFB (Order No. 613380), e.g. in the case of a PE liner, which must be anchored relative to a shaft wall.



PE 100

Maximum shear load per FIXBLOC: 40 kN

d_1	Order No.	H	h1	L	B	Weight [kg]	BX	PU	Stock status
160 - 1600	680600	40	45	220	60	0.310	15	750	1



ASA TL

Top-loading sewage saddle

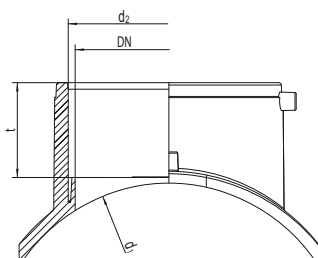

Top-loading sewage saddle ASA TL, SDR 17

- Compact component made from HD-PE with integrated fusion coupler in the outlet (d 160)
- For a connection for connecting pipes to existing PE main channel
- Safety technology

Note:

Can only be used with clamping and drilling device FWFIT (Order No. 613480).

For d 200, special installation instructions must be observed when applying to SDR 33-11 pipes and for d 225-d 315 to SDR 33-26 pipes.



PE 100

Maximum permissible working pressure 2.5 bar

d ₁	d ₂	DN	Order No.	t	Weight [kg]	BX	PU	Stock status
200	160	150	682618	76	1.000	8	64	1
225	160	150	682613	76	1.050	8	64	1
250	160	150	682619	76	0.990	10	80	1
280	160	150	682614	76	0.990	10	80	1
315	160	150	682615	76	0.990	10	80	1
355	160	150	682620	76	0.990	10	80	1
400	160	150	682621	76	0.890	10	80	1
450	160	150	682616	76	1.020	10	80	1
500/560/630	160	150	682622	76	1.020	10	80	1

For installation on close-fit liners and pipes d 560/d 630, please contact our hotline +49 621 486-1896.



ASA TL KG

Top-loading transition saddle

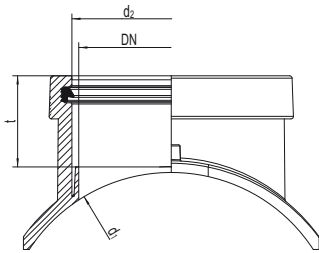

Transition saddle, top-Loading ASA TL KG, SDR 17

- Compact component made from HD-PE with integral socket in the outlet (d 160)
- For connecting connecting pipes made of PVC/PP DN 150 to existing PE main channel
- Safety technology

Note:

Can only be used with clamping and drilling device FWFIT (Order No. 613480).

For d 225 - d 315, special installation instructions must be observed when applying to SDR 33 - 26 pipes.



PE 100

Maximum permissible test pressure 0.5 bar to DIN EN 1610

d ₁	d ₂	DN	Order No.	t	Weight [kg]	BX	PU	Stock status
225	160	150	682624	76	1.192	8	64	1
280	160	150	682625	76	1.106	10	80	1
315	160	150	682626	76	1.106	10	80	1
355	160	150	682627	76	1.106	10	80	1
450	160	150	682628	76	1.136	10	80	1
500/560/630	160	150	682629	76	1.136	10	80	1

For installation on close-fit liners and pipes d 560/d 630, please contact our hotline +49 621 486-1896.



ASA UNI

Spigot saddle SDR 17

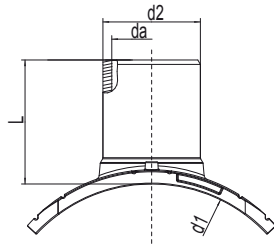

Spigot saddle with outlet spigot ASA UNI, SDR 17

- For the connection of a branch pipe into PE pipes without pressure or under working pressure
- Compact component made of HD-PE saddle with safety technology
- Outlet spigot for processing with FRIAFIT couplers AM
- For variable adaptation to all pipe diameters in the specified range by means of clamping device
- With indicator for visual inspection of the fusion

Note:

Can only be used with clamping device UNITOP (Order No. 613385) and clamping adaptor for outlet SDR 17 (Order No. 613839).

For pressure-free tapping, we recommend our drilling equipment FWAB (Order No. 613838).



PE 100

Maximum permissible working pressure 2.5 bar (sewage)

d ₁	d ₂	Order No.	Weight [kg]	BX	PU	Stock status
630-900	160	682639	1.650	5	40	1



ASA VL

Vacuum-loading sewage saddle

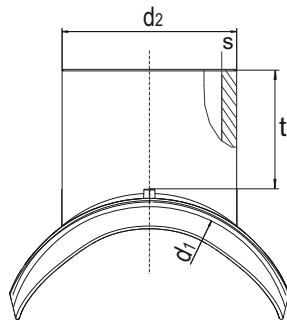

Sewage saddle vacuum loading ASA VL, SDR 17

- For the integration of large-volume branch pipes to collectors made of HD-PE with little effort, minimal foundation engineering and without interruption of operation
- HD-PE saddle with safety technology
- When using SDR 17/17,6 pipes, the outlet spigot d 225 provide a passage with an equal base
- Can be fused with FRIAFIT couplers AM or transition socket AMKG d 225 on PVC/PP DN 200
- Innovative vacuum clamping technology for reliable bridging of even large pipe ovality and shape deviations, which additionally provides the possibility of a tightness test before drilling



Note:

Can be used with the vacuum pump VACUPUMP only (Order No. 613827) and the corresponding plunger PRESSKO (Order No. 613823). For pressure-free tapping, we recommend our drilling equipment FWAB (Order No. 613835). The ASA VL assembly aid (Order No. 613371) is also required for cross-dimensional processing.

PE 100

Maximum permissible working pressure 2.5 bar (sewage)

d ₁	d ₂	Order No.	t	s	Weight [kg]	BX	PU	Stock status
355	225	682640	144	13,4	3.080	1	4	1
450	225	682641	144	13,4	2.900	1	6	1
560	225	682642	144	13,4	3.065	1	6	1
630	225	682643	144	13,4	3.080	1	6	1

Cross-dimension processing

Ø pipe	d ₂	Order No.
315 400	225	682640
500	225	682641
710	225	682643



ASA MULTI

Connecting spigot to clay and concrete pipes

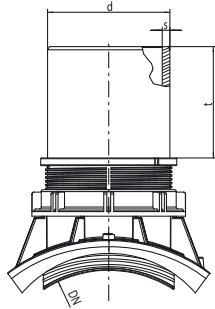

Connecting spigot to clay and concrete pipes ASA MULTI

- For the connection of fused, root-proof HD-PE connection pipes to clay or concrete pipes
- For reinstallation as well as refurbishment without separation or complete opening of the main trench
- When using SDR 17/17,6 pipes, the outlet connection d 160 offers a passage with the same sole
- Bright inner surface of the spigot for optimum visibility when driving through the camera
- Can be fused with FRIAFIT coupler AM or FRIAFIT bends ABM/ABMS

Note:

For installation, the ASA MULTI MS assembly key (Order No. 682660) will be required.

PE 100

Maximum permissible test pressure 0.5 bar to DIN EN 1610

	Pipe	d	Order No.	H	B	t	s	Weight [kg]	BX	PU	Stock status
1)	STZ DN 250	160	682650	250	265	146	9,5	2.700	5	40	1
2)	STZ DN 300/350	160	682651	250	265	146	9,5	2.800	5	40	1
3)	Concrete DN 250/300	160	682651	250	265	146	9,5	2.800	5	40	1

- 1) Suitable for connection to clay pipes DN 250 N/H (standard and high load series EN 295)
- 2) Suitable for connection to clay pipes DN 300 / DN 350 N/H (standard and high load series EN 295)
- 3) Suitable for connection to concrete pipes DN 250 / DN 300 (EN 1916)

ASA MULTI MS

Assembly key

Assembly key ASA MULTI MS

- For secure and fast installation of FRIAFIT connector spigots ASA MULTI



Order No.	Weight [kg]	Stock status
682660	0.150	1



ABM

Sewage bend

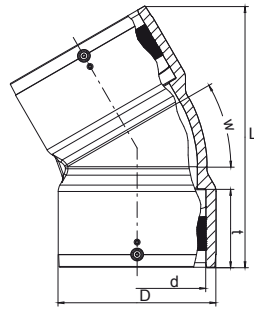

Sewage bend (coupler/coupler) ABM

- Low space requirement through compact design
- The elbow gradations 15°, 30°, 45° enable comfortable services routing
- Couplers integrated on both sides to reduce assembly time with safety technology
- The smooth and hydraulically optimised internal contour provides a equal-base passage when utilising SDR 17/17.6 pipes
- Bright surface finish for optimum visibility when driving through with a camera
- With pin indicator for visual inspection of the fusion

PE 100

Maximum permissible working pressure 2.5 bar

d	w	Order No.	D	L	t	Weight [kg]	BX	PU	Stock status
160	15°	681100	185	279	92	1.870	6	48	1
160	30°	681101	185	306	92	2.100	6	48	1
160	45°	681102	185	320	92	2.060	6	48	1

ABMS

Sewage bend (one-side spigot end)

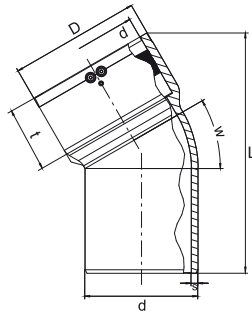

Sewage bend (one-side spigot end) ABMS

- Low space requirement through compact design. The gradations 15°, 30°, 45° enable comfortable services routing
- Fem. connection side with safety technology
- Pipe spigot particularly suitable for direct fusion into the FRIAFIT sewage saddle ASA TL
- By multiple application with ABM, for example, elbows of 60°, 90°, etc. can also be achieved
- The smooth and hydraulically optimised internal contour provides a equal-base passage when utilising SDR 17/17.6 pipes
- Bright surface finish for optimum visibility when driving through with a camera
- With pin indicator for visual inspection of the fusion.

PE 100

Maximum permissible working pressure 2.5 bar

d	w	Order No.	D	L	t	s	Weight [kg]	BX	PU	Stock status
160	15°	681103	185	286	92	9,5	1.510	6	48	1
160	30°	681104	185	329	92	9,5	1.680	6	48	1
160	45°	681105	185	325	92	9,5	1.730	6	48	1

AMKG

Transition coupler PE-PVC/PP

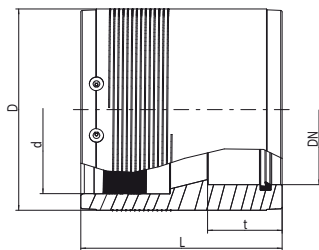

Transition coupler PE-PVC/PP AMKG

- Continuous material transfer from HD-PE pipes (SDR 33 - 17) to PVC/PP pipes
- HD-PE side with integrated coupler with safety technology
- PVC/PP side as coupler with SBR lip seal with large insertion depth

PE 100

Maximum permissible test pressure 0.5 bar to DIN EN 1610

d/DN	Order No.	D	L	t	Weight [kg]	BX	PU	Stock status
160/150	682630	193	183.5	80	1.780	1	120	1
225/200	682631	270	270	100	5.820	1	32	1



UKG

Transition piece PE-PVC/PP

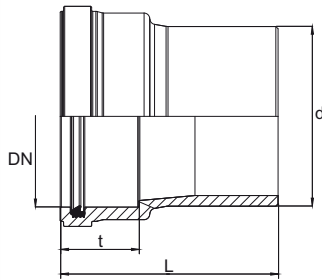

Transition piece PE-PVC/PP UKG

- Continuous material transfer from HD-PE pipes (SDR 33 - 17) to PVC/PP pipes
- HD-PE side can be fused with FRIAFIT AM coupler, bend ABM/ABMS or with FRIAFIT ASA TL sewage saddles
- PVC/PP side as coupler with SBR lip seal with large insertion depth

PE 100

Maximum permissible test pressure 0.5 bar to DIN EN 1610

d/DN	Order No.	L	t	Weight [kg]	BX	PU	Stock status
160/150	682617	194	70	1.070	12	96	1

USTZ

Transition piece PE - clay

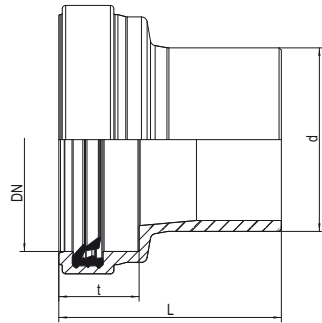

Transition fitting PE - clay USTZ

- Continuous material transfer from HD-PE pipes (SDR 33 - 17) to clay pipes (spigot end)
- HD-PE side can be fused with FRIAFIT AM coupler, bend ABM/ABMS or with FRIAFIT ASA TL sewage saddles
- Clay side as coupler with SBR lip seal with large insertion depth.

PE 100

Maximum permissible test pressure 0.5 bar to DIN EN 1610

d/DN	Order No.	L	t	Weight [kg]	BX	PU	Stock status
160/150	682623	194	70	1.250	2	36	1



FRIAFIT additional fittings

ABS 15

15° sewage bend (spigot fitting)

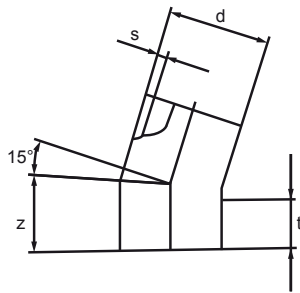

Sewage bend 15°, SDR 17 (spigot fitting) ABS 15

- HD-PE fitting for processing without holding devices with FRIAFIT couplers AM
- Black pipe colour with bright inner surface (subject to availability)

PE 80 / PE 100

Maximum permissible test pressure 0.5 bar to DIN EN 1610

d	Order No.	Z	t	s	Weight [kg]	BX	Stock status
110	681004	230	170	6,6	1.050	1	3
125	681005	250	170	7,4	1.450	1	3
160	681006	280	170	9,1	2.780	1	3
180	681007	315	250	10,2	3.770	1	3
225	681008	370	250	12,8	6.870	1	3
355	681023	438	300	15,9	12.500	1	3
355	681020	528	300	20,1	24.300	1	3

ABS 30

30° sewage bend (spigot fitting)

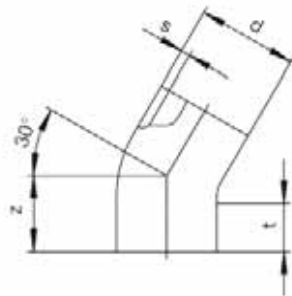

Sewage bend 30°, SDR 17 (spigot fitting) ABS 30

- HD-PE fitting for processing without holding devices with FRIAFIT couplers AM
- Black pipe colour with bright inner surface (subject to availability)

PE 80 / PE 100

Maximum permissible test pressure 0.5 bar to DIN EN 1610

d	Order No.	Z	t	s	Weight [kg]	BX	Stock status
110	681009	230	170	6,6	1.050	1	3
125	681010	250	170	7,4	1.450	1	3
160	681001	280	170	9,1	2.780	1	3
180	681002	317	250	10,2	3.770	1	3
225	681003	371	250	12,8	6.870	1	3
280	681022	440	300	15,9	12.500	1	3
315	681021	480	300	17,9	17.400	1	3
355	681019	520	300	20,1	22.100	1	3



ABS 45

45° sewage bend (spigot fitting)

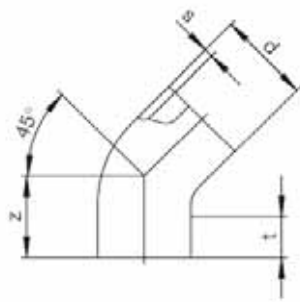

Sewage bend 45°, SDR 17 (spigot fitting) ABS 45

- HD-PE fitting for processing without holding devices with FRIAFIT couplers AM
- Black pipe colour with bright inner surface (subject to availability)

PE 80 / PE 100

Maximum permissible test pressure 0.5 bar to DIN EN 1610

d	Order No.	Z	t	s	Weight [kg]	BX	Stock status
110	681011	235	170	6,6	1.050	3	3
125	681012	250	170	7,4	1.450	3	3
160	681201	280	170	9,1	2.780	1	3
180	681202	320	250	10,2	3.770	1	3
200	681203	349	250	11,4	5.000	1	3
225	681204	380	250	12,8	6.870	1	3
250	681205	411	250	14,2	9.210	1	3
280	681206	448	300	15,9	12.500	1	3
315	681207	491	300	17,9	17.400	1	3
355	681208	541	300	20,1	24.300	1	3

ABS 90

90° sewage bend (spigot fitting)

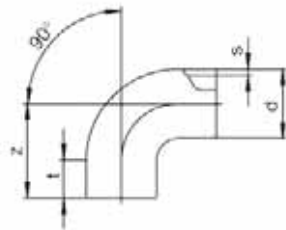

Sewage bend 90°, SDR 17 (spigot fitting) ABS 90

- HD-PE fitting for processing without holding devices with FRIAFIT couplers AM
- Black pipe colour with bright inner surface (subject to availability)

PE 80 / PE 100

Maximum permissible test pressure 0.5 bar to DIN EN 1610

d	Order No.	Z	t	s	Weight [kg]	BX	Stock status
160	681601	390	100	9,1	3.230	1	3
180	681602	420	150	10,2	4.370	1	3
225	681603	488	150	12,8	7.440	1	3



ATS 45

Equal branch 45° (spigot fitting)

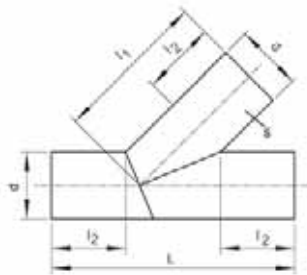

Equal branch with same outlet 45°, SDR 17 (spigot fitting) ATS 45

- HD-PE fitting for processing without holding devices with FRIAFIT couplers AM
- Black pipe colour with bright inner surface (subject to availability)

PE 80 / PE 100

Maximum permissible test pressure 0.5 bar to DIN EN 1610

d	Order No.	L	l1	l2	s	Weight [kg]	BX	Stock status
110	682001	556	333	200	6,6	1.700	1	3
125	681013	577	351	200	7,4	2.300	1	3
160	682002	626	393	200	9,5	4.100	1	1
180	682003	655	417	200	10,7	5.400	1	3
200	682004	783	491	250	11,9	8.000	1	3
225	682005	818	522	250	13,4	10.500	1	3
250	682006	954	602	300	14,8	15.100	1	3
280	682007	996	638	300	16,6	19.700	1	3
315	682008	1145	730	350	18,7	28.800	1	3
355	682009	1202	779	350	21,1	38.300	1	3

ATSR 45

Unequal branch 45° (spigot fitting)

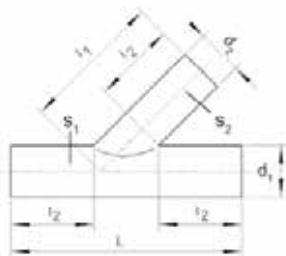

Unequal branch with reduced outlet 45°, SDR 17 (spigot fitting) ATSR 45

- HD-PE fitting for processing without holding devices with FRIAFIT couplers AM
- Black pipe colour with bright inner surface (subject to availability)

PE 80 / PE 100

Maximum permissible test pressure 0.5 bar to DIN EN 1610

d ₁	d ₂	Order No.	L	l1	l2	s ₁	s ₂	Weight [kg]	BX	Stock status
160	110	682201	556	368	200	9,5	6,6	3.100	1	3
225	160	682203	726	489	250	13,4	9,5	8.000	1	3
280	160	682204	826	578	300	16,6	9,5	13.100	1	3
280	225	682205	918	610	300	16,6	13,4	16.300	1	3
315	160	682206	926	653	350	18,7	9,5	18.100	1	3
315	225	682207	1018	685	350	18,7	13,4	21.900	1	3
355	160	682208	926	681	350	21,1	9,5	22.400	1	3
355	225	682209	1018	714	350	21,1	13,4	26.700	1	3
450	160	682210	926	748	350	26,7	9,5	34.800	1	3



FRIAFIT additional fittings

ATSRS 45

Unequal branch 45° with off-center outlet (spigot fitting)

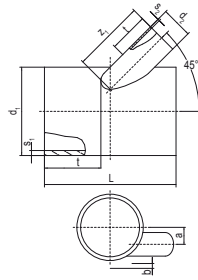

Unequal branch 45° with off-center outlet, SDR 17 (spigot fitting) ATSRS 45

- HD-PE fitting with off-center outlet for processing without holding devices with FRIAFIT couplers AM.
- Black pipe colour with bright inner surface (subject to availability)

Note:

The required outlet side (right/left) in the flow direction must be specified when ordering.

PE 80 / PE 100

Maximum permissible test pressure 0.5 bar to DIN EN 1610

d ₁	d ₂	Order No.	L	t	z ₁	s ₁	s ₂	a	b	Weight [kg]	BX	Stock status
315	160	682301	630	200	320	17,9	9,1	50	30	13.400	1	3
315	225	682302	720	200	320	17,9	12,8	20	25	17.400	1	3
355	160	682303	630	200	335	20,1	9,1	68	30	16.600	1	3
355	225	682304	720	200	335	20,1	12,8	40	25	20.900	1	3
450	160	682305	670	200	370	25,5	9,1	115	30	26.600	1	3
450	225	682306	760	200	370	25,5	12,8	87	25	32.300	1	3
560	160	682307	670	200	410	31,7	9,1	170	30	39.900	1	3
560	225	682308	760	200	410	31,7	12,8	142	25	47.600	1	3
630	160	682309	670	200	440	35,7	9,1	205	30	49.900	1	3
630	225	682310	760	200	440	35,7	12,8	177	25	59.100	1	3

ATSRS 90

Unequal branch 90° with off-center outlet (spigot fitting)

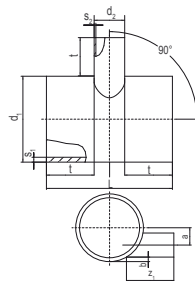

Unequal branch 90° with off-center outlet, SDR 17 (spigot fitting) ATSRS 90

- HD-PE fitting with off-center outlet for processing without holding devices with FRIAFIT couplers AM
- Black pipe colour with bright inner surface (subject to availability)

PE 80 / PE 100

Maximum permissible test pressure 0.5 bar to DIN EN 1610

d ₁	d ₂	Order No.	L	t	z ₁	s ₁	s ₂	a	b	Weight [kg]	BX	Stock status
315	160	682401	565	200	280	17,9	9,1	50	30	12.100	1	3
315	225	682402	630	200	280	17,9	12,8	20	25	15.300	1	3
355	160	682403	660	200	290	20,1	9,1	68	30	17.000	1	3
355	225	682404	730	200	290	20,1	12,8	40	25	20.700	1	3
450	160	682405	660	200	315	25,5	9,1	115	30	25.600	1	3
450	225	682406	730	200	315	25,5	12,8	87	25	30.700	1	3
560	160	682407	660	200	340	31,7	9,1	170	30	39.000	1	3
560	225	682408	730	200	340	31,7	12,8	142	25	45.300	1	3
630	160	682409	660	200	360	35,7	9,1	205	30	48.800	1	3
630	225	682410	730	200	360	35,7	12,8	177	25	56.200	1	3



FRIAFIT additional fittings

CDE Sewage end cap (spigot fitting)

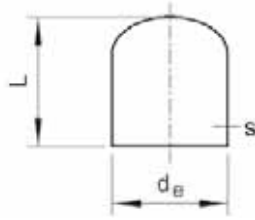

Sewage end cap (spigot fitting) CDE

- HD-PE fitting for processing without holding devices with FRIAFIT couplers AM.

PE 100

Maximum permissible test pressure 0.5 bar to DIN EN 1610

de	Order No.	L	s	Weight [kg]	BX	Stock status
110	73409636110	127	6,6	0.275	18	1
125	73409636125	127	7,4	0.360	18	1
160	73409636160	155	9,5	0.740	6	1
180	73409636180	166	10,7	0.975	12	2
225	73409636225	203	13,4	1.805	6	1
280	73409636280	238	16,6	3.285	6	1
315	73409636315	258	18,7	4.610	2	1
355	73409636355	281	21,1	6.610	2	2
400	73409636400	310	23,7	9.185	2	1

RES Reducer off-center (spigot fitting)

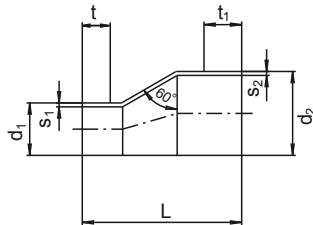

Reducer off-center, SDR 17 (spigot fitting) RES

- HD-PE fitting for processing without holding devices with FRIAFIT couplers AM

PE 80 / PE 100

Maximum permissible test pressure 0.5 bar to DIN EN 1610

d ₁	d ₂	Order No.	L	t	t ₁	s ₁	s ₂	Weight [kg]	BX	Stock status
110	125	681018	264	85	85	6,6	7,4	1.000	1	3
110	160	681801	310	90	95	6,6	9,5	1.200	1	3
160	225	681802	404	100	150	9,5	13,4	2.530	1	3
200	225	681804	440	100	250	11,9	12,8	4.100	1	3
225	280	681810	540	150	250	13,4	16,6	5.460	1	3





FRIATOOLS[®] Technical Equipment

Convenient and durable devices and tools for the pipe connection.

Product range EZ 35/22

Things worth knowing about FRIATOOLS® Technical Equipment and this product range

FRIAMAT area of application

FRIAMAT electrofusion units operate reliably at ambient temperatures from -20 °C to +50 °C. The range of application depends on the power requirement of the fitting to be fused and the respective processing temperature. For the processing of FRIAMAT and FRIAFIT couplers, Aliaxis Deutschland recommends the use of FRIAMAT 7 prime, FRIAMAT 7 basic, FRIAMAT prime eco, FRIAMAT print eco and FRIAMAT basic eco to dimension d 900 and from FRIAMAT XL to d 1200 over the entire processing temperature range.

FRIAMAT fusion units can be used to process fittings from other manufacturers even up to d 1200 and above. However, first clarify with the fitting manufacturer the specific power requirement of the fitting at the prevailing processing temperature.

Availability of the FRIAMAT Bluetooth function and the FRIAMAT APP

FRIAMAT 7 prime and FRIAMAT prime eco are equipped with a Bluetooth® interface. The availability of the Bluetooth function in the FRIAMAT fusion unit and thereby the possibility of using the FRIAMAT APP is not provided everywhere and depends on the country of use and the type of the fusion unit. In which country the Bluetooth function and the FRIAMAT app can be utilised, please refer to the respective operating instructions or further explanations on our homepage at www.aliaxis.de/en/services/digital-apps.





The FRIAMAT 7 prime and FRIAMAT 7 basic

The 7. FRIAMAT Generation fulfils your needs even better

We have now enhanced our FRIAMAT fusion units, which have been tried and tested many times, up to the latest technological level and have made them "fit for the future". To make it easier for you to work - in every respect. This new low weight device provides high performance, easier/more convenient operation and documentation.

FRIAMAT 7 basic is one of our most successful models, which we have comprehensively revised to include features such as: Flow-optimized active cooling, rugged housing, bright colour TFT display, intuitive user guidance and much more.

FRIAMAT 7 prime also offers you the full range of digital functions for documentation and advanced traceability alongside the new Bluetooth interface and FRIAMAT app. With the optional 1D/2D scanner, the new FRIAMAT is also prepared to read out and process 2D barcodes according to ISO 12176-5. This enables you to capture all the information

required for fusing, including traceability data and advanced product information with just one scan operation.



FRIAMAT 7 with the tried and tested mini scanner

FRIAMAT 7 prime Fusion unit with documentation function



Powerful universal fusion unit FRIAMAT 7 prime

- Bluetooth
- Full documentation
- Full traceability functions
- 20,000 fusion protocols
- Output via USB interface or app (smart phone)
- Supervisor function
- State-of-the-art converter technology with active cooling.
- Bright colour TFT display
- With mini scanner, reader wand or 1D/2D scanner (2D barcodes according to ISO 12176-5)
- Extra long fusion cable (4 m)
- Extra long power cable (5 m)
- Weight approx. 12.8 kg

Note:

Possibility of updating the FRIAMAT software via the USB interface by the user.

Version	Order No.	Stock status
With reader wand	613134	1
With mini scanner	611134	1
With 1D/2D scanner	614134	1

FRIAMAT prime eco Fusion unit with documentation function



Powerful universal fusion unit FRIAMAT prime eco

- Bluetooth
- Full documentation
- full traceability functions
- 20,000 fusion protocols
- Output via USB interface or app (smart phone)
- Supervisor function
- State-of-the-art toroidal core technology with active cooling.
- Bright colour TFT display
- With mini scanner, reader wand or 1D/2D scanner (2D barcodes according to ISO 12176-5)
- Extra long fusion cable (4 m)
- Extra long power cable (5 m)
- Weight approx. 18.0 kg

Note:

Possibility of updating the FRIAMAT software via the USB interface by the user.

Version	Order No.	Stock status
With reader wand	613124	1
With mini scanner	611124	1
With 1D/2D scanner	614124	3 NEW



FRIAMAT 7 basic Fusion unit without documentation function



Powerful universal fusion unit FRIAMAT 7 basic
State-of-the-art converter technology with active cooling.

- Bright colour TFT display
- With mini scanner, reader wand or 1D/2D scanner (2D barcodes according to ISO 12176-5)
- Extra long fusion cable (4 m)
- Extra long power cable (5 m)
- Weight approx. 12.8 kg

Note:

Possibility of updating the FRIAMAT software via the USB interface by the user.

Version	Order No.	Stock status
With reader wand	613130	1
With mini scanner	611130	1
With 1D/2D scanner	614130	1

FRIAMAT basic eco Fusion unit without documentation function



Powerful universal fusion unit FRIAMAT basic eco

- State-of-the-art toroidal transformer technology with active cooling
- Bright colour TFT display
- With mini-scanner, reader wand or 1D/2D scanner (2D barcodes according to ISO 12176-5)
- Extra long fusion cable (4 m)
- Extra long power cable (5 m)
- Weight approx. 18.0 kg

Note:

Possibility of updating the FRIAMAT software via the USB interface by the user.

Version	Order No.	Stock status
With reader wand	613120	1
With mini scanner	611120	1
With 1D/2D scanner	614120	3 NEW



FRIATOOLS fusion units - accessories

MINISCAN

Mini-scanner



FRIAMAT mini-scanner

- Handy
- Sturdy
- Reliable reading of the fusion barcodes and traceability barcodes
- Practical storage bag
- Suitable for all FRIAMAT fusion units in this current catalogue for FRIATOOLS

Note:

Utilisation with older FRIAMAT types on request.

Order No.

624005

**Stock
status**

1

FWLESST

Reader wand



FRIAMAT reader wand

- For reading in the fusion and traceability barcodes
- Applicable to all FRIAMAT fusion units

Order No.

623645

**Stock
status**

1

2DSCAN

1D/2D scanner



FRIAMAT 1D/2D Scanner

- Handy
- Sturdy
- Reliable reading of 1D fusion and traceability barcodes and 2D barcodes according to ISO 12176-5.
- With practical storage pocket
- Suitable for all FRIAMAT fusion units in this current catalogue for FRIATOOLS

Order No.

624006

**Stock
status**

1

MEMSTICK

Memory stick



FRIAMAT Memory-Stick for storing fusion data and traceability data

- As FRIATRACE database format
- As a PDF data file or CSV data file
- 2GB

Order No.

624023

**Stock
status**

1



FRIATRACE FRIATRACE database software



Software for further processing of fusion data including traceability data (traceability)

- Suitable for:
 - Windows XP
 - Windows 7
 - Windows 8.1
 - Windows 10
- For FRIAMAT fusion units with traceability and documentation function
- With database function (all fusion data in a database)
- For individual evaluation, copying, sorting, searching, formatting, editing, etc.
- FRIATRACE database software consisting of:
 - FRIATRACE CD-ROM
 - Connection cable PC fusion unit
- FRIATRACE combo package consisting of:
 - FRIATRACE CD-ROM
 - Memory Stick (2GB)

Note:

The FRIATRACE database software will be discontinued soon and replaced by a digital offer available on www.aliaxis.de.

Article description	Order No.	Stock status
FRIATRACE database software	613280	1
FRIATRACE combination package	624026	1

PA USB FRIAMAT Parallel USB Adapter



For connecting a printer with USB Type B port.

- For FRIAMAT fusion units from year 2000 with parallel interface
- Direct printing of fusion data on a USB printer
- GDI printers are not supported.

Note:

Power is supplied via the supplied power supply (adapter included).

Order No.	Stock status
613263	1

SUPER P Supervisor Pass



For individual setting of menu functions.

- Function blocking
- Presetting of forced processes
- Controlling the maintenance deadline
- Other functions (see FRIAMAT operating instructions)

Usable for:

- FRIAMAT 7 prime
- FRIAMAT prime eco
- FRIAMAT XL

Note:

To order, please download the application form on www.aliaxis.de in the product catalogue under Supervisor Pass.

Order No.	Stock status
623101	3



FRIATOOLS fusion units - accessories

SPASS

Fusion-Pass



To block the fusion unit functions

- Identification of the person fusing
- To protect FRIAMAT fusion units (only documentation devices) from unauthorised access

The data stored in the Fusion-Pass (fusion number or name of the person fusing) will be transferred to the fusion protocol.

Note:

To order, please download the application form on www.aliaxis.de in the product catalogue under Fusion-Pass.

Order No.	Stock status
623100	3

FPASS

Remote start pass



For remote start of all FRIAMAT fusion units

- With reader wand
- With scanner
- Including carrying belt

Note:

Reading in the code only activates the START button. Unable to stop fusion unit.

Order No.	Stock status
624003	1

ALTK FMT

Transport boxes



For transporting and storing FRIAMAT fusion units.

Note:

Transport boxes for older FRIAMAT types available on request.

Version	Order No.	Stock status
FRIAMAT prime / basic (until model year 2020)		
FRIAMAT 7 prime / 7 basic	627600	1
FRIAMAT prime eco / basic eco (from model year 2018)		
FRIAMAT prime eco / basic eco / geo print (until model year 2018)	627001	1

CONTACT4

Socket contacts 4.0 mm



Socket contacts 4.0 mm

- For all FRIAMAT fusion units

Order No.	Stock status
624529	1



ADFL

Adaptor for flat contacts

- For mounting on the socket contact 4.0 mm
- For all FRIAMAT fusion units
 - Adaptor for flat contacts



Order No.

613236

Stock status

1

ADBK

Adaptor for socket contacts 4.7 mm

- For mounting on the socket contact 4.0 mm
- For all FRIAMAT fusion units
 - Adaptor with socket contact 4.7 mm



Order No.

613237

Stock status

1

We make your job easier: Good reasons for the practical scraper tools

The right hand tools always make the decisive difference on the construction site. Ensuring that our tried and tested scraper tools are even more comfortable and user friendly.



FWSG 63 for pipes d 20 - d 63

- Universal scraper areas, no dimensional adjustment required
- Interchangeable blade with second cutting blade for double service life



FWSG 225 for pipes d 75 - d 225

- Rapid adjusting for easy adjustment of the scraper length
- Interchangeable blade with second cutting blade for double service life



FWSG 400 for pipes d 75 - d 400

- Rapid adjusting for easy adjustment of the scraper length
- Interchangeable blade with second cutting blade for double service life

FRIATOOLS scraper tools

FWSG RA

Compact scraper tool for pipe ends and outlet spigots d 25 - d 63

Dimension-bound compact scraper tool FWSG RA

- Metal version
- Safe removal of the oxide layer from HD-PE and PE-Xa pipes and from outlet spigots on FRIALEN fittings
- Extra-long scraper length
- Scraper blade made of hard metal with 2 cutting edges (double life)
- Automatic compensation of pipe ovality and tolerances
- Operation by hand, with hand crank or battery-operated screwdriver.



Note:

Practical plastic case to hold dimensions d 32 - d 63 available as an accessory (without compact scraper tools).

Article description	Dimension	SDR	Order No.	Stock status
FWSG RA 25	d 25	SDR 11	613576	1
FWSG RA 32	d 32	SDR 11	613580	1
FWSG RA 40	d 40	SDR 11	613581	1
FWSG RA 50	d 50	SDR 11	613582	1
FWSG RA 63	d 63	SDR 11	613583	1
Crank handle	All dimensions		613579	1
FWSG RA case	d 32 - d 63		613586	1

FWSG 63

Scraper tool for pipes d 20 – d 63 (1/2" - 2" IPS)

Cross-dimension scraper tool FWSG 63

- Safe removal of the oxide layer from HD-PE and PE-Xa pipes
- Scraper blade made of hard metal with 2 cutting edges (double life)
- Universal scraper areas from d 20 - d 63 (1/2" - 2" IPS)
- No dimension adjustment required
- Uniform chip removal by spring-mounted scraper blade and automatic feed
- Delivery in transport box



Article description	Dimension	Order No.	Stock status
FWSG 63	d 20 - d 63	613408	1

FWSG 225

Scraper tool for pipes d 75 – d 225 (3" - 8" IPS)

Cross-dimension scraper tool FWSG 225

- Safe removal of the oxide layer from HD-PE and PE-Xa pipes
- Scraper blade made of hard metal with 2 cutting edges (double life)
- Universal scraping areas from d 75 - d 225 (3" - 8" IPS)
- Uniform chip removal by spring-mounted scraper blade and automatic feed
- With quick adjustment for easy adjustment to the scraping length
- Delivery in transport box



Article description	Dimension	Order No.	Stock status
FWSG 225	d 75 - d 225	613409	1

FWSG 400

Scraper tool for pipe d 75 - d 400 (3" - 14" IPS)

Cross-dimension scraper tool FWSG 400

- Safe removal of the oxide layer from HD-PE and PE-Xa pipes
- Scraper blade made of hard metal with 2 cutting edges (double life)
- Universal scraping areas from d 75 - d 400 (3" - 14" IPS)
- Uniform chip removal by spring-mounted scraper blade and automatic feed
- With quick adjustment for easy adjustment to the scraping length
- Delivery in transport box



Article description	Dimension	Order No.	Stock status
FWSG 400	d 75 - d 400	613410	1



FRIATOOLS scraper tools

FWSG 710 L Scraper tool for pipes d 250 – d 710 (10” - 28” IPS)



Cross-dimensional scraper tool FWSG 710 L

- Safe removal of the oxide layer from HD-PE and PE-Xa pipes
- Scraper blade made of hard metal (long service life)
- Universal scraping areas from d 250 - d 710 (10” - 28” IPS)
- Uniform chip removal by spring-mounted scraper blade and automatic feed
- With quick adjustment for easy adjustment to the scraping length
- Delivery in transport box

Article description	Dimension	Order No.	Stock status
FWSG 710 L	d 250 - d 710	613642	1

FWSG 710 S Scraper tool for pipes d 250 – d 710 (10” - 28” IPS) and spigot fittings



Cross-dimensional scraper tool FWSG 710 S

- Safe removal of the oxide layer from HD-PE and PE-Xa pipes (maximum for half-socket length d 710)
- Scraper blade made of hard metal (long service life)
- Universal scraping areas from d 250 - d 710 (10” - 28” IPS)
- Uniform chip removal by spring-mounted scraper blade and automatic feed
- With quick adjustment for easy adjustment to the scraping length
- Delivery in transport box

Article description	Dimension	Order No.	Stock status
FWSG 710 S	d 250 - d 710	613639	1

FWSG 900 L Scraper tool for pipes d 630 - d 900 (25” - 36” IPS)



Cross-dimensional scraper tool FWSG 900 L

- Safe removal of the oxide layer from HD-PE and PE-Xa pipes
- Scraper blade made of hard metal (long service life)
- Universal scraping areas from d 630 - d 900 (25” - 36” IPS)
- Uniform chip removal by spring-mounted scraper blade and automatic feed
- With quick adjustment for easy adjustment to the scraping length
- Delivery in transport box

Article description	Dimension	Order No.	Stock status
FWSG 900	d 630 - d 900	613644	3

FWSG XL Large scraper tool for pipes d 800 to d 1200



Cross-dimension scraper tool FWSG XL

- Safe removal of the oxide layer from HD-PE and PE-Xa pipes SDR 11 - SDR 33
- Scraper blade made of hard metal with 2 cutting edges (double life)
- Universal scraper areas from d 800 - d 1200
- Centrally supported drive unit via hand crank
- Uniform chip removal by spring-mounted scraper blade and automatic feed
- With quick adjustment for easy adjustment to the scraping length
- Delivery in transport box

Article description	Dimension	Order No.	Stock status
FWSG XL	d 800 - d 1200	613645	3



FRIATOOLS scraper tools

FWSG SE

Compact scraper tool for pipe ends and saddle surfaces d 63 - d 315



Dimension-bound scraper tool FWSG SE

- Safe removal of the oxide layer from HD-PE and PE-Xa pipes and in the saddle surface area
- Scraper blade with 2 cutting edges (double life)
- Easy clamping due to the open design of the scraper tool.
- Uniform chip removal by spring-mounted scraper blade
- Delivery in transport box

Article description	Dimension	Order No.	Stock status
FWSG SE 63	d 63	613562	1
FWSG SE 75	d 75	613563	1
FWSG SE 90	d 90	613564	1
FWSG SE 110	d 110	613565	1
FWSG SE 125	d 125	613566	1
FWSG SE 140	d 140	613567	1
FWSG SE 160	d 160	613568	1
FWSG SE 180	d 180	613569	1
FWSG SE 200	d 200	613570	1
FWSG SE 225	d 225	613571	1
FWSG SE 250	d 250	613572	1
FWSG SE 280	d 280	613573	1
FWSG SE 315	d 315	613574	1

FWSG SE IPS

Scraper tool for pipe ends and saddle areas 2 IPS - 12 IPS



Dimension-bound scraper tool FWSG SE IPS

- Safe removal of the oxide layer from HD-PE and PE-Xa pipes and in the saddle surface area
- Scraper blade with 2 cutting edges (double life)
- Easy clamping due to the open design of the scraper tool.
- Uniform chip removal by spring-mounted scraper blade
- Delivery in transport box

Article description	Dimension	Order No.	Stock status
FWSG SE 2 IPS	2 IPS	613512	1
FWSG SE 3 IPS	3 IPS	613513	1
FWSG SE 4 IPS	4 IPS	613514	1
FWSG SE 6 IPS	6 IPS	613515	1
FWSG SE 8 IPS	8 IPS	613516	1
FWSG SE 12 IPS	12 IPS	613519	1

FWSK

Scraper chain for pipe ends and saddle surfaces d 250 - d 1000



Cross-dimension scraper tool FWSK

- Safe removal of the oxide layer from HD-PE and PE-Xa pipes and in the saddle surface area
- Simple clamping
- Adjustable pipe diameter
- Uniform chip removal by spring-mounted scraper blade
- Delivery in transport box

Article description	Dimension	Order No.	Stock status
FWSK	d 250 - 1000	613383	1



FWSGE 3 Replacement blade for scraper tools FWSG 225 (until 2019)



Replacement blade made of hard metal FWSGE 3

- 3 pieces Replacement blade
- 1 piece Torx screw
- 1 piece Torx wrench.

Note:

Can only be utilised for scraper tools FWSG 225 and FWSG 315 up to model year Q3/2019.

Article description	Unit type	Marking	Order No.	Stock status
FWSGE 3	FWSG 225 / FWSG 315 (up to model year Q3/2019)	Red coloured	613322	1

FWSGE 4 Replacement blades for scraper tools FWSG 63 (until 2018)



Replacement blade made of hard metal FWSGE 4

- 3 pieces Replacement blade
- 1 piece Torx screw
- 1 piece Torx wrench.

Note:

Can only be utilised for the FWSG 63 scraper tool up to model year 2018.

Article description	Unit type	Marking	Order No.	Stock status
FWSGE 4	FWSG 63 (up to model year 2018)	Green coloured	613323	1

FWSGE 5 Replacement blade for scraper tools FWSG 710 L/S and FWSG 900 L



Replacement blade made of hard metal FWSGE 5

- 3 pieces Replacement blade
- 1 piece Torx screw
- 1 piece Torx wrench

Article description	Unit type	Marking	Order No.	Stock status
FWSGE 5	FWSG 710 L/S and FWSG 900 L	Blue coloured	613324	1

FWSGE 6 Replacement blade for scraper tools FWSGS 110 and FWSGS 180

Replacement blade made of hard metal FWSGE 6

- 1 piece Replacement blade
- 2 piece Torx screw
- 1 piece Torx wrench

Article description	Unit type	Order No.	Stock status
FWSGE 6	FWSGS 110 / FWSGS 180	613325	1

FWSGE 8 Replacement blades for scraper tools FWSG SE (all types)



Replacement blades FWSGE 8

- Design as a turning blade (with 2 cutting edges).
- 1 piece Replacement blade
- 1 piece Allen screw
- 1 piece Allen wrench

Article description	Unit type	Order No.	Stock status
FWSGE 8	FWSG SE (all types)	613327	1



FWSGE 10

Replacement blades for scraper tools FWSG RA 32 and 40

Replacement blades FWSGE 10

- Design as a turning blade (with 2 cutting edges).
- 1 piece Replacement blade
- 1 piece Torx screw
- 1 piece Torx wrench



Article description	Unit type	Order No.	Stock status
FWSGE 10	FWSG RA 32 and 40	613329	1

FWSGE 11

Replacement blades for scraper machines FWSG RA 50 and 63

Replacement blades FWSGE 11

- Design as a turning blade (with 2 cutting edges).
- 1 piece Replacement blade
- 1 piece Torx screw
- 1 piece Torx wrench



Article description	Unit type	Order No.	Stock status
FWSGE 11	FWSG RA 50 and 63	613330	1

FWSGE 12

Replacement blades for scraper tools FWSG XL

Replacement blades and sliding plate FWSGE 12 designed for large pipe machining

- Design as reversing blade and reversing plate (with 2 cutting edges).
- 1 piece Replacement blade
- 1 piece sliding plate
- 1 piece Torx screw
- 1 piece Torx wrench



Article description	Unit type	Order No.	Stock status
FWSGE 12	FWSG XL	613331	1

FWSGE 13

Replacement blades for scraper tools FWSG RA 25

Replacement blades FWSGE 13

- Design as a turning blade (with 2 cutting edges).
- 1 piece Replacement blade
- 1 piece Torx screw
- 1 piece Torx wrench



Article description	Unit type	Order No.	Stock status
FWSGE 13	FWSG RA 25	613332	1

FWSGE 14

Replacement blades for scraper tools FWSG 225 / FWSG 400 (from 2019)

Replacement blades FWSGE 14

- Design as a turning blade (with 2 cutting edges).
- 1 piece Replacement blade
- 1 piece Torx screw
- 1 piece Torx wrench



Note:

FWSGE 14 can only be utilised for the scraper tools FWSG 225 and FWSG 400 from model year 2019.

Article description	Unit type	Marking	Order No.	Stock status
FWSGE 14	FWSG 225/FWSG 400 (from model year 2019)	white coloured	613335	1

FWSGE 15

Replacement blades for scraper tools FWSG 63 (from 2018)

Replacement blades FWSGE 15

- Design as a turning blade (with 2 cutting edges).
- 1 piece Replacement blade
- 1 piece Torx screw
- 1 piece Torx wrench



Note:

FWSGE 15 can only be used for the FWSG 63 scraper tool from model year 2018.

Article description	Unit type	Marking	Order No.	Stock status
FWSGE 15	FWSG 63 (from model year 2018)	Orange coloured	613336	1

FWSGE K

Replacement blades for scraper chain FWSK

Replacement blades for scraper chain

Article description	Unit type	Order No.	Stock status
FWSGE K	FWSK	613337	1

ALTK FWSG

Transport boxes

For transporting and storing scraper tools.

Note

Transport boxes for older scraper tools on request.



Unit type	Order No.	Stock status
FWSG 63	613307	1
FWSG 225 and FWSG 63/225 (up to model year 2019)	613309	1
FWSG 225 (from model year 2019)	613406	1
FWSG 400 (from model year 2019)	613407	1
FWSG 710 S	613308	1
FWSG 710 L	613314	1
FWSG 900 L	613304	1
FWSG SE 63	613303	1
FWSG SE 75 - 140	613319	1
FWSG SE 160 - 225	613318	1
FWSG SE 250 - 315	613320	1



FWZ

Hand scraper

For removing the oxide layer from HD-PE pipes or mouldings which cannot be processed by appropriate scraper tools. Also suitable for deburring cut edges.

- 1 hand piece scraper



Note

Replacement blades: Content per pack 5 piece.

Article description	Order No.	Stock status
Hand scraper	613300	1
Replacement blade	613270	1

FWZ XL

Hand scraper for large pipes

For removing the oxide layer from large PE pipes which cannot be processed by appropriate scraper tools. In particular for preparing saddle surfaces for processing FRIAL XL saddle mouldings. Also suitable for deburring cut edges.

- 1 hand scraper
- Two cutting faces



Article description	Order No.	Stock status
Hand scraper for large pipes	613299	1



FRIATOP

Clamping unit (top loading)



For assembling FRIALEN XL top-loading saddle mouldings without lower clamp.

- For all pipe diameters in the respective stated dimension range with extra elastic pneumatic spring
- For optimum joint pressure build-up during fusing.

Order No.	Stock status
613350	1



UNITOP

Clamping unit for spigot saddles SA UNI / ASA UNI



For the assembly of:

- FRIALEN Spigot Saddles SA UNI d 250 - d 900 with outlet d 90, d 110, d 125 and d 160
- FRIAFIT Spigot Saddles ASA UNI d 630 - d 900 with outlet d 160 / SDR 17.

Note:

In conjunction with the UNITOP clamping device, additional elbow adaptors ADWL for socket contacts 4.0 mm are required for fusion units equipped with straight-line fusion plugs (Order No. 613241). Not required for FRIAMAT fusion units.

For the correct mounting of the FRIAFIT Spigot Saddle ASA UNI d 630 - d 900 with outlet d 160 / SDR 17, an additional adaptor (Order No. 613839) will be required for drilling. This adapter must be ordered separately.

Article description	Order No.	Stock status
UNITOP clamping device from d 250 - d 900	613385	1
ADWL elbow adaptor for socket contacts 4.0 mm	613241	1
Clamp adaptor for the outlet of the ASA UNI d 160 spigot saddles	613839	1



VACUPUMP

Vacuum pump with connection pipes



- For assembly on
- FRIALEN spigot saddles SA VL,
 - FRIALEN repair saddles RS VL,
 - FRIAFIT Sewage saddles ASA VL.

- Comprising:
- Vacuum pump 230V
 - Gauge
 - Connection pipes.

Note

No additional site compressor is required for operation. Delivery in transport box.

Plungers (PRESSKO) are required for the installation of FRIALEN spigot saddles SA VL and FRIAFIT sewage saddles ASA VL.



Article description	Order No.	Stock status
Vacuum pump 230 V	613827	1
Vacuum pump 110V	613828	3

PRESSKO

Plunger



Nominal size-related plunger with stop plate and plug-in nipple NW 7.2 for assembling on:

- FRIALEN spigot saddle SA VL with outlet d 160, d 225 or d 250
- FRIAFIT sewage saddle ASA VL with outlet 225 and for connecting the VACUBOX.

Note:

Plunger for other outlet dimensions up to d 400 on request.



Version	Order No.	Stock status
FRIALEN SA VL d 160	613821	1
FRIALEN SA VL d 225	613822	1
FRIALEN SA VL d 250 / FRIAFIT ASA VL d 225	613823	1
FRIALEN SA VL d 280	613853	1
FRIALEN SA VL d 315	613854	1
FRIALEN SA VL d 355	613855	1
FRIALEN SA VL d 400	613837	1



FWAB

Drilling equipment



FWAB drilling equipment for drilling HD-PE pipes in a pressure-free condition:

- Spigot saddles SA VL
- FRIALEN spigot saddles SA UNI
- FRIAFIT spigot saddles ASA UNI
- FRIAFIT sewage saddles ASA VL
- Driven by drill

Comprising:

- Hole saw (nominal size-related), hole saw mounting with drill shaft SDS-maximum,
- Extension for hole saw mounting (not for FWAB ASA as well as for SA UNI applications),
- Centring drill with ejector and catch sleeve
- Hexagonal spanner.



Note:
(Fig. shows FWAB XL 160)

Article description	Outlet dimension	Order No.	Stock status
FWAB XL 90 for FRIALEN SA UNI	d 90	613832	1
FWAB XL 110 for FRIALEN SA UNI	d 110	613833	1
FWAB XL 125 for FRIALEN SA UNI	d 125	613834	1
FWAB XL 160 for FRIALEN SA UNI	d 160	613829	1
FWAB XL 225 for FRIALEN SA VL	d 225	613830	1
FWAB XL 250 for FRIALEN SA VL	d 250	613831	3
FWAB XL 280 for FRIALEN SA VL	d 280	613850	3
FWAB XL 315 for FRIALEN SA VL	d 315	613851	1
FWAB XL 355 for FRIALEN SA VL	d 355	613852	1
FWAB XL 400 for FRIALEN SA VL	d 400	613836	3
FWAB XL 160 for FRIAFIT ASA UNI	d 160	613838	1
FWAB ASA 225 for FRIAFIT ASA VL	d 225	613835	1

FWFIT

Clamping and drilling unit for FRIAFIT sewage saddles (ASA TL) and transition saddles (ASA TL KG)

Combined clamping and drilling device FWFIT, universally applicable for:

- FRIAFIT ASA TL sewage saddles
- Transition saddle ASA TL KG
- For clamping and producing the necessary joining pressure during fusion
- For drilling through the outlet in the pressure-free condition after expiry of the prescribed cooling time



Order No.	Stock status
613480	1



ASATOP

Clamping unit for close-fit liner DN 200 - DN 500 (ASA TL) and transition saddle (ASA TL KG)



Clamping tool ASATOP for processing from:

- FRIAFIT sewage saddles ASA TL
- ASA TL KG transition saddles, especially for HD-PE close-fit liners DN 200 - DN 500 and for HD-PE pipes d 630
- For clamping and producing the necessary joining pressure during fusion

Comprising:

- ASATOP clamping device with tilting dowel (without pipe-comprehensive clamping belt technology)
- Hole saw (Ø 95 mm) with SDS hole saw holder
- Centring drill,
- Extension,
- Compressed air pump



Note:

The FWFIT clamping device and drilling device (Order No. 613480) will be required for drilling.

Order No.	Stock status
613370	3

RPS

Repair set



RPS repair set for retaining residual water after the water runs

- When executing repair work and integration work on HD-PE water pipes in dimensions d 90 to d 900

■ Comprising:

- Universal repair set with pump
- Gauge
- Drill
- Connection hose
- In addition, dimensional repair balloons

- Optional extension kit for the universal repair set for connecting another repair balloon

■ Comprising:

- Connection hose 3 m
- Gauge



Note:

From dimension d 355 onwards, the drilling equipment FWAB XL 225 (Order No. 613830) is required for drilling.

When utilising the repair set up to d 225, then FRIALEN repair and reinforcing saddles VVS are required. From d 250, FRIALEN locking clamps VSC TL or FRIALEN repair saddles RS VL will be required.

Article description	Dimension	Order No.	Stock status
Universal repair set	All dimensions	613701	1
Extension kit	All dimensions	613715	1
Repair balloon Type 1	d 90 - d 180	613702	1
Repair balloon Type 2	d 200 - d 315	613703	1
Repair balloon Type 3	d 355 - d 450	613704	1
Repair balloon Type 4	d 500 - d 560	613705	1
Repair balloon Type 5	d 630	613706	1
Repair balloon Type 6	d 710	613707	1
Repair balloon Type 7	d 800	613708	1
Repair balloon Type 8	d 900	613709	1
Transport box		613700	1



CLAMP 63

Alignment clamp d 20 - d 63



Pipe retaining clamp CLAMP 63 with elbow adjustment (45° / 90°)
 Universal application for:

- Fitting
- Reductions
- Elbow 45° and 90°
- Outlets on saddle components d 20 - d 63 mm

Note:

Optional long version CLAMP63L can also be used for long couplers FRIALONG.

Article description	Order No.	Stock status
CLAMP63	613020	1
CLAMP63L	613034	1

CLAMP 180

Alignment clamp d 63 - d 180



Pipe retaining clamp CLAMP 180 with elbow adjustment (45° / 90°) and 2 clamping elements for:

- Fittings,
- Reductions
- Elbow 45° and 90° in d 63, d 90, d 125 and d 180
- Modular expansion of the pipe retaining clamp.
 - 2 additional clamping elements for utilisation as 4-fold retaining clamps for dimensions d 63, d 90, d 125 and d 180.
 - T-extension kit for pipe clamp can be utilised for T-pieces. Can be upgraded by additional clamping element to the double retaining clamp on the branching pipe.
 - Reducer half-shell set for dimensions d 110 and d 160.

(Fig. shows design with 4 clamping elements)

Article description	Dimension	Order No.	Stock status
Pipe retaining clamp with 2 clamping elements	d 63, d 90, d 125, d 180	613021	1
Additional clamping element (1 piece.)	d 63, d 90, d 125, d 180	613022	1
Reducer half-shell set (1 piece)	d 110, d 160	613023	1
T extension kit	d 63, d 90, d 125, d 180	613024	1

SQM

Manual squeezing-off tool for d 20 - d 125 pipes



SQM manual squeezing-off tool for the temporary shut-off of HD-PE and PE-Xa pipes d 63 - d 125 in SDR 11 and SDR 17,6.

Article description	Dimension	SDR	Order No.	Stock status
SQM63	d 20 - d 63	SDR 11	613025	1
SQM125	d 63 - d 90 d 90 - d 125	SDR 11, SDR 17,6	613026	1

SQH

Hydraulic squeeze-off tool for pipes d 63 - d 180



SQH hydraulic squeeze-off tool for the temporary shut-off of HD-PE and PE-Xa pipes d 63 - d 180 in SDR 11 and SDR 17.6.

Article description	Dimension	SDR	Order No.	Stock status
SQH180	d 63 - d 180	SDR 11 / SDR 17,6	613028	1



RRC

Re-rounding clamps for reinstating round cross section of squeezed-off pipes d 63 - d 180

For rounding back HD-PE and PE-Xa pipes d 63 - d 180 after squeezing has been executed correctly.

- RRC90 as universal rounding-back clamp for dimensions d 63, d 75 and d 90. Including key for actuating the universal return clamp
- RRC110 - RRC180 as dimension-related rounding-back clamps for dimensions d 110, d 125, d 160 and d 180

(Fig. 1 shows RRC90, Fig. 2 shows RRC180)



Article description	Dimension	Order No.	Stock status
RRC90	d 63, d 75, d 90	613029	3
RRC110	d 110	613030	3
RRC125	d 125	613031	3
RRC160	d 160	613032	3
RRC180	d 180	613033	3

FWXR

Manual round clamp for pipes d 63 - d 250

For the back rounding of oval HD-PE and PE-Xa pipes. Cover several dimensions by inserting reducing half-shells.

(Fig. shows FWXR-S1)



Article description	Dimension	Order No.	Stock status
FWXR-S1	d 32, d 40, d 50, d 63	613416	1
FWXR-S2	d 90, d 110	613431	1
FWXR-S3	d 125, d 160	613439	1
FWXR-S4	d 180, d 200	613443	3
FWXR-S5	d 225, d 250	613444	3

FWXRH

Hydraulic round clamp for pipes d 280 - d 900

For rounding back HD-PE and PE-Xa pipes.

Note:
Prices and availability of dimensions on request.

(Fig. shows the hydraulic round clamp d 800).



Dimension	Order No.	Stock status
d 280	613452	3
d 315	613461	3
d 355	613462	3
d 400	613463	3
d 450	613464	3
d 500	613465	3
d 560	613467	3
d 630	613466	3
d 710	613468	3
d 800	613460	3
d 900	613458	3



FRIATOOLS other tools and installation aids

FWXRB

Manual rounding clamp for pipes d 800 - d 1200



For rounding back HD-PE pipes.
Suitable for pipes d 800 - d 1200.

Note:
Prices and availability on request.

Dimension	Order No.	Stock status
d 800 - d 1200	613457	3

PCUT

Pipe cutter for pipes d 20 - d 140

Pipe cutter with quick adjustment for HD-PE pipes d 20 to d 140 in SDR 11.



Article description	Dimension	Order No.	Stock status
Pipe cutter d 63	d 20 - d 63	613040	1
Pipe cutter d 140	d 50 - d 140	613041	1
Replacement cutting wheel d 63	d 20 - d 63	613042	1
Replacement cutting wheel d 140	d 50 - d 140	613043	1

PCUT S

Pipe shears for pipes d 20 - d 63

Pipe shears with lever ratio for HD-PE pipes d 20 to d 63 in SDR 11.



Article description	Dimension	Order No.	Stock status
Pipe shears d 40	d 20 - d 40	613044	1
Pipe shears d 63	d 20 - d 63	613046	1

FWPM

FRIALEN/FRIAFIT marker (silver)

For labelling HD-PE and PE-Xa pipes.

- Colour silver
- Content per pack: 10 pieces.



Order No.	Stock status
613069	1



FWSS

Activating key for tapping tees

For drill actuation, depending on the diameter (d1) of the FRIALEN tapping tees

- DAA RED SNAP
- DAA Classic
- DAA TL
- DAA TL RE

Note

Wrench size SW17 mm is also suitable for drill actuation of all SABs.



d ₁	WS [mm]	Order No.	Stock status
1) 40-225	17	613246	1
2) 90-315	19	613250	1

- 1) An activating key SW17 mm for all DAA RED SNAP, SAB, DAA Classic d 50 - d 75 and DAP d 63.
- 2) Suitable for DAA TL and DAA TL RE as well as DAA Classic d 90 - d 225, and DAP d 90 - d 225.



FWSR T

Ratchet for activating key for tapping tees DAA RED SNAP

For drill actuation of the DAA RED SNAP FRIALEN tapping tees, comprising: Ratchet 1/2" telescopic including socket wrench attachment SW17 (17 mm).

Note:

In addition, the actuating key FWSS SW17 mm is required (Order No. 613246).



Article description	Order No.	Stock status
Ratchet 1/2" with socket wrench SW17 mm	613615	1



FWSR

Actuating key for parallel dome tapping tees (DAP)

For drill actuation of the FRIALEN tapping tees with parallel dome DAP, comprising:

- Ratchet 1/2"
- Socket adapter



Article description	Order No.	Stock status
Ratchet 1/2"	613610	1
Socket key SW 19 mm	613605	1
Socket key SW 17 mm	613606	1



FRIATOOLS other tools and installation aids

FWDPA

Pressure test adapter for DAA Classic, DAP, DAA TL, DAA TL RE

Pressure test adaptor for use with FRIALEN tapping tees:

- DAP
- DAA TL
- DAA Classic from d 90, with female thread = R 1/4" for connecting a pressure gauge



Article description	Order No.	Stock status
FWDPA for FRIAL DAP, DAA TL, DAA Classic from d 90	613595	1

FWDPA

Pressure test adapter for DAA RED SNAP

NEW

Drill sleeve with pressure sampling adapter for use with FRIALEN tapping tees DAA RED SNAP with female thread = R 1/4" for connecting a pressure gauge.



Article description	Order No.	Stock status
FWDPA for FRIALEN DAA RED SNAP	613597	1

FWDPA SA

Pressure test adapter

Pressure test adaptor for use with FRIALEN spigot saddles SA UNI, with connection nipple Ø 1/2".



Article description	Order No.	Stock status
FWDPA SA for SA UNI	613596	1



FRIATOOLS rental equipment service

FRIATOOLS rental equipment service



Aliaxis Deutschland offers the right equipment for every processing situation. In addition to FRIAMAT fusion units and FRIATOOLS scraper tools, a comprehensive range of tools and installation equipment for processing FRIALEN safety fittings and the FRIAFIT sewage system can be rented.



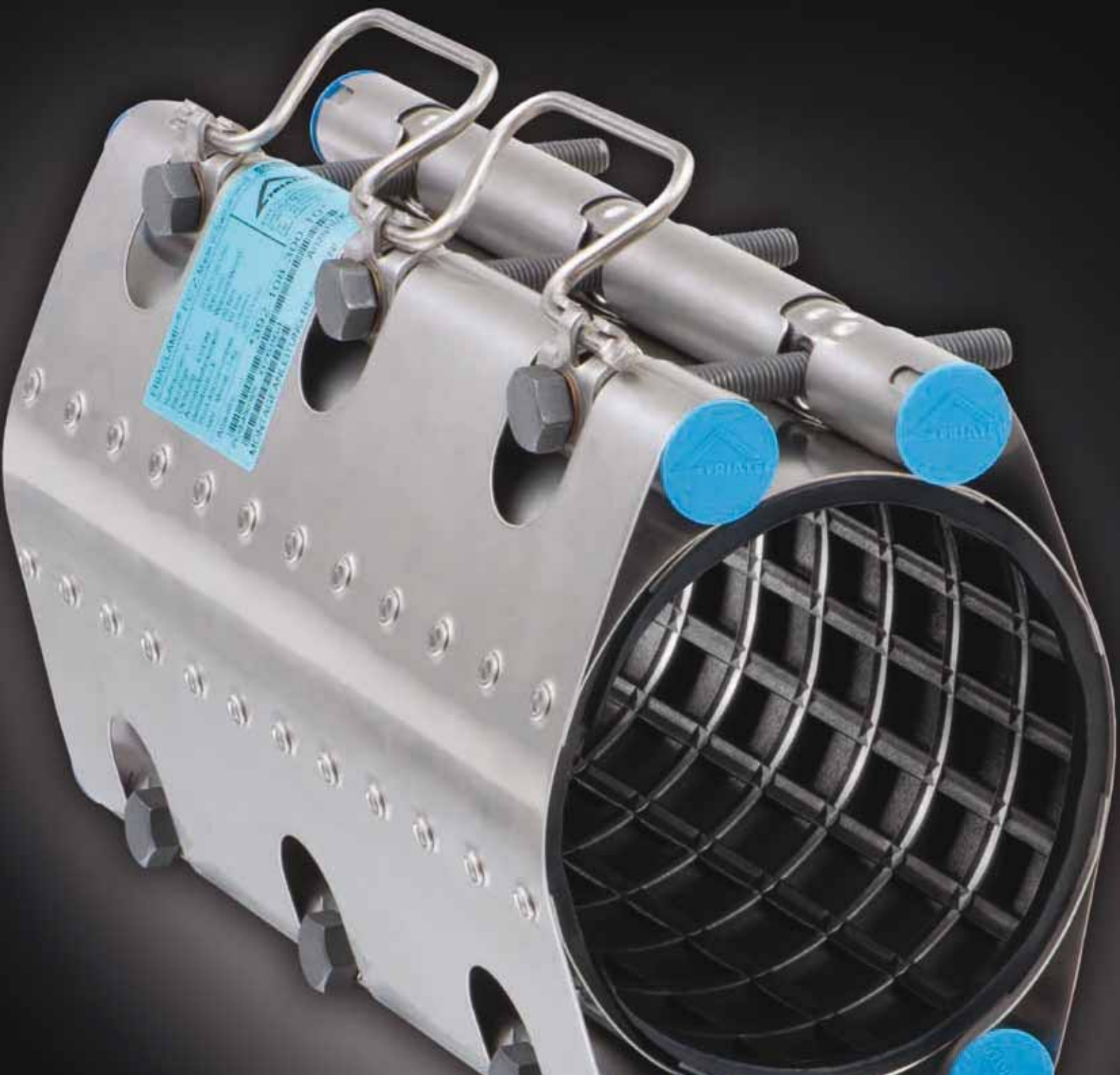

FRIACLAMP stainless steel repair clamp

Product range HE 21/22

FRIACLAMP

FCE

FRIACLAMP stainless steel repair clamp, one-piece



One-piece repair clamp for sealing damaged gas and water pipes made of steel, cast iron, ductile iron, asbestos cement and PVC.

- Special sealing design for secure sealing of bores, cracks and corrosion damage
- Body, lock, screws and nuts made of stainless steel
- Sealing material EPDM or NBR

Permissible working pressure FCE (water)

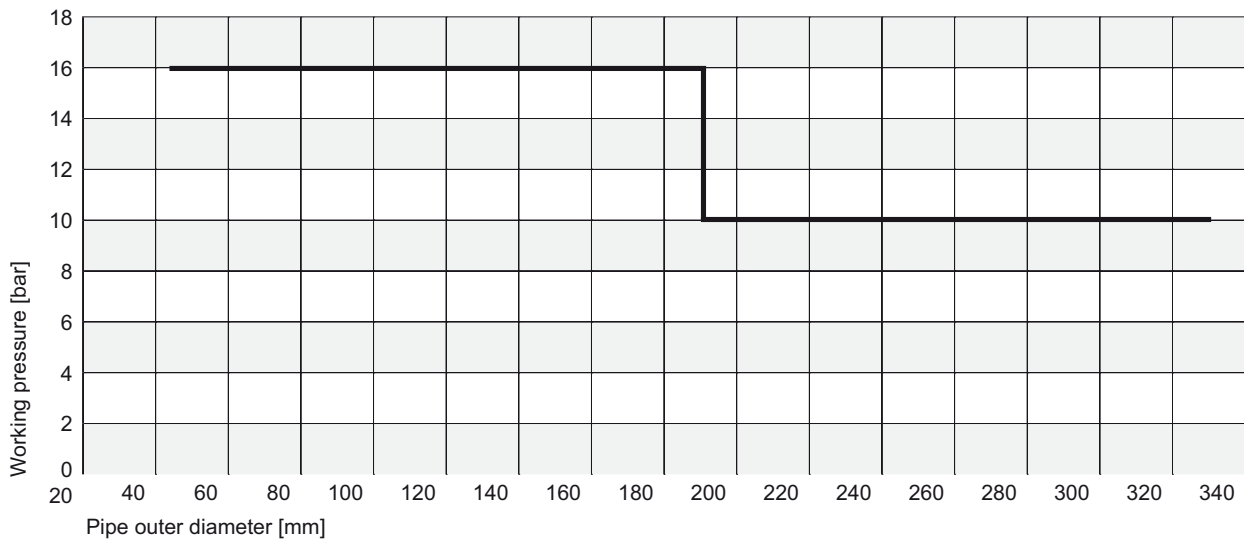

Gasket EPDM, DIN-EN 681-1 / KTW / UBA / DVGW-W270
PFA/PN water according to table, maximum = 16 bar



d	Installation length	Order No.	Weight [kg]	BX	PU	Stock status
44-48	200	391-044-200	1.410	10	320	3
44-48	300	391-044-300	2.140	10	240	3
48-52	200	391-048-200	1.440	10	320	1
48-52	300	391-048-300	2.190	10	240	1
54-58	200	391-054-200	1.480	10	320	1
54-58	300	391-054-300	2.250	10	240	1
60-67	200	391-060-200	1.530	10	320	1
60-67	300	391-060-300	2.330	10	240	1
70-77	200	391-070-200	1.610	9	288	3
70-77	300	391-070-300	2.440	9	216	3
75-83	200	391-075-200	1.650	9	288	1
75-83	300	391-075-300	2.500	9	216	3
82-89	200	391-082-200	1.710	9	288	1
82-89	300	391-082-300	2.580	9	216	3
82-89	400	391-082-400	3.450	9	96	3
87-95	200	391-087-200	1.740	9	288	1
87-95	300	391-087-300	2.650	9	216	1
87-95	400	391-087-400	3.520	9	96	3
88-98	200	391-088-200	1.760	8	256	1
88-98	300	391-088-300	2.670	8	192	1
95-104	200	391-095-200	1.830	6	192	1
95-104	300	391-095-300	2.870	6	144	1
95-104	400	391-095-400	3.820	6	96	1
108-118	200	391-108-200	1.910	6	144	1
108-118	300	391-108-300	3.020	6	144	1
108-118	400	391-108-400	4.020	6	96	1



FRIACLAMP

FCE

FRIACLAMP stainless steel repair clamp, one-piece

Gasket EPDM, DIN-EN 681-1 / KTW / UBA / DVGW-W270
PFA/PN water according to table, maximum = 16 bar



d	Installation length	Order No.	Weight [kg]	BX	PU	Stock status
113-123	200	391-113-200	2.030	5	160	1
113-123	300	391-113-300	3.070	5	120	1
113-123	400	391-113-400	4.090	5	80	1
118-128	200	391-118-200	2.070	5	160	3
118-128	300	391-118-300	3.130	5	120	3
118-128	400	391-118-400	4.170	5	80	3
120-131	200	391-120-200	2.180	5	160	3
120-131	300	391-120-300	3.300	5	90	3
132-142	200	391-132-200	2.270	4	128	3
132-142	300	391-132-300	3.440	4	96	1
135-145	200	391-135-200	2.300	4	128	3
135-145	300	391-135-300	3.480	4	96	1
139-149	200	391-139-200	2.330	4	128	3
139-149	300	391-139-300	3.520	4	96	1
139-149	400	391-139-400	3.570	4	64	3
145-155	200	391-145-200	2.370	4	128	3
145-155	300	391-145-300	3.590	4	96	3
159-170	200	391-159-200	2.490	3	96	1
159-170	300	391-159-300	3.760	3	72	1
159-170	400	391-159-400	5.010	3	48	3
167-178	200	391-167-200	2.550	3	96	3
167-178	300	391-167-300	3.860	3	72	1
167-178	400	391-167-400	5.140	3	48	1
176-187	200	391-176-200	3.120	3	96	3
176-187	300	391-176-300	4.730	3	72	3
176-187	400	391-176-400	6.310	3	48	3
193-203	200	391-193-200	3.270	1	36	3
193-203	300	391-193-300	4.950	1	36	3
215-225	200	391-215-200	3.470	1	32	3
215-225	300	391-215-300	5.250	1	24	1
215-225	400	391-215-400	7.000	1	16	3
228-239	300	391-228-300	5.420	1	24	3
240-250	300	391-240-300	5.650	1	24	3
261-271	300	391-261-300	5.930	1	24	3
269-280	300	391-269-300	6.040	1	24	3
280-291	300	391-280-300	6.190	1	24	3
315-325	300	391-315-300	6.650	1	24	3
320-330	300	391-320-300	6.720	1	24	3

FRIACLAMP



FRIACLAMP

FCE

FRIACLAMP stainless steel repair clamp, one-piece

Gasket NBR, DIN-EN 682

MOP gas according to table, maximum = 5 bar

Other water qualities according to table, maximum = 16 bar



d	Installation length	Order No.	Weight [kg]	BX	PU	Stock status
44-48	200	381-044-200	1.410	10	320	3
48-52	200	381-048-200	1.440	10	320	1
48-52	300	381-048-300	2.190	10	240	3
54-58	200	381-054-200	1.480	10	320	1
54-58	300	381-054-300	2.250	10	240	1
60-67	200	381-060-200	1.530	10	320	1
70-77	200	381-070-200	1.610	9	288	1
75-83	200	381-075-200	1.650	9	288	1
82-89	200	381-082-200	1.710	9	288	1
87-95	200	381-087-200	1.740	9	288	1
87-95	300	381-087-300	2.650	9	216	1
88-98	200	381-088-200	1.760	8	256	1
95-104	200	381-095-200	1.830	6	192	1
95-104	300	381-095-300	2.870	6	144	1
108-118	200	381-108-200	1.910	6	144	1
108-118	300	381-108-300	3.020	6	144	1
113-123	200	381-113-200	2.030	5	160	1
113-123	300	381-113-300	3.070	5	120	1
113-123	400	381-113-400	4.090	5	80	1
120-131	200	381-120-200	2.180	5	160	3
132-142	200	381-132-200	2.270	4	128	1
139-149	300	381-139-300	3.520	4	96	1
159-170	200	381-159-200	2.490	3	96	1
159-170	300	381-159-300	3.760	3	72	1
167-178	200	381-167-200	2.550	3	96	1
167-178	300	381-167-300	3.860	3	72	1
215-225	200	381-215-200	3.470	1	32	1
215-225	300	381-215-300	5.250	1	24	1



FCZ

FRIACLAMP stainless steel repair clamp, two-piece



Two-piece repair clamp for sealing damaged gas and water pipes made of steel, cast iron, ductile iron, asbestos cement and PVC.

- Special sealing design for secure sealing of bores, cracks and corrosion damage
- Body, lock, screws and nuts made of stainless steel
- Sealing material EPDM or NBR

Permissible working pressure FCZ (water)

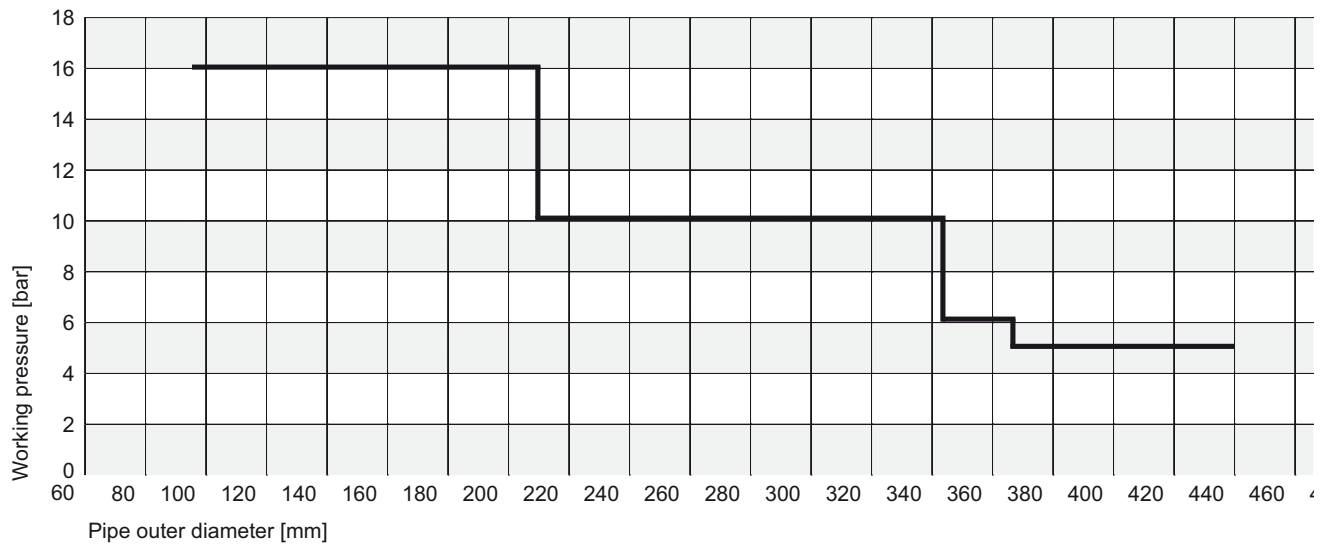

Gasket EPDM, DIN-EN 681-1 / KTW / UBA / DVGW-W270
 PFA/PN water according to table, maximum = 16 bar



d	Installation length	Order No.	Weight [kg]	BX	PU	Stock status
88-110	200	392-088-200	2.820	6	192	1
88-110	300	392-088-300	4.260	6	144	1
88-110	400	392-088-400	5.710	6	96	3
100-120	200	392-100-200	2.680	4	192	3
100-120	300	392-100-300	4.060	4	144	3
100-120	400	392-100-400	5.430	4	96	3
108-128	200	392-108-200	2.730	4	128	1
108-128	300	392-108-300	4.170	4	96	1
108-128	400	392-108-400	5.580	4	64	3
114-134	200	392-114-200	2.810	4	128	3
114-134	300	392-114-300	4.250	4	96	3
114-134	400	392-114-400	5.690	4	64	3
120-140	200	392-120-200	3.000	4	128	3
120-140	300	392-120-300	4.540	4	96	3
120-140	400	392-120-400	6.080	4	64	3
130-150	200	392-130-200	3.150	3	64	3
130-150	300	392-130-300	4.760	3	48	3
130-150	400	392-130-400	6.380	3	16	3
140-160	200	392-140-200	3.230	3	64	3
140-160	300	392-140-300	4.890	3	48	3
140-160	400	392-140-400	6.540	3	16	3
159-180	200	392-159-200	3.390	2	64	1
159-180	300	392-159-300	5.130	2	48	1
159-180	400	392-159-400	6.860	2	16	3
168-189	200	392-168-200	3.460	2	64	3
168-189	300	392-168-300	5.240	2	48	3
168-189	400	392-168-400	7.010	2	16	3



FCZ

FRIACLAMP stainless steel repair clamp, two-piece

Gasket EPDM, DIN-EN 681-1 / KTW / UBA / DVGW-W270
 PFA/PN water according to table, maximum = 16 bar



d	Installation length	Order No.	Weight [kg]	BX	PU	Stock status
190-210	200	392-190-200	4.600	2	64	3
190-210	300	392-190-300	6.970	2	48	3
190-210	400	392-190-400	9.350	2	16	3
210-230	200	392-210-200	4.810	1	32	1
210-230	300	392-210-300	7.290	1	24	3
210-230	400	392-210-400	9.770	1	16	3
218-238	200	392-218-200	4.910	1	32	3
218-238	300	392-218-300	7.440	1	24	3
218-238	400	392-218-400	9.960	1	16	3
240-260	200	392-240-200	5.160	1	32	3
240-260	300	392-240-300	7.820	1	24	3
240-260	400	392-240-400	10.470	1	16	3
269-289	200	392-269-200	5.430	1	32	3
269-289	300	392-269-300	8.220	1	24	3
269-289	400	392-269-400	11.010	1	16	3
282-302	200	392-282-200	5.550	1	32	3
282-302	300	392-282-300	8.400	1	24	3
282-302	400	392-282-400	11.250	1	16	3
315-335	200	392-315-200	5.860	1	32	3
315-335	300	392-315-300	8.860	1	24	3
315-335	400	392-315-400	11.870	1	16	3
322-344	300	392-322-300	8.970	1	24	3
322-344	400	392-322-400	12.010	1	16	3
337-358	300	392-337-300	9.170	1	24	3
337-358	400	392-337-400	12.280	1	36	3
347-367	300	392-347-300	9.310	1	36	3
347-367	400	392-347-400	12.460	1	16	3
365-385	400	392-365-400	12.790	1	32	3
410-430	400	392-410-400	15.120	1	24	3
420-440	400	392-420-400	15.330	1	16	3

Gasket NBR, DIN-EN 682
 MOP gas according to table, maximum = 5 bar
 Other water qualities according to table, maximum = 16 bar



d	Installation length	Order No.	Weight [kg]	BX	PU	Stock status
88-110	200	382-088-200	2.820	6	192	1
88-110	300	382-088-300	4.260	6	144	1
88-110	400	382-088-400	5.710	6	96	1
108-128	200	382-108-200	2.730	4	128	1
108-128	300	382-108-300	4.170	4	96	1
108-128	400	382-108-400	5.580	4	64	1
114-134	300	382-114-300	4.250	4	96	3
130-150	200	382-130-200	3.150	3	64	1
130-150	300	382-130-300	4.760	3	48	1
140-160	200	382-140-200	3.230	3	64	1
140-160	300	382-140-300	4.890	3	48	1
159-180	200	382-159-200	3.390	2	64	1
159-180	300	382-159-300	5.130	2	48	1
210-230	200	382-210-200	4.810	1	32	1
218-238	400	382-218-400	9.960	1	16	3
315-335	300	382-315-300	8.860	1	24	3



Notes

A series of horizontal dotted lines for writing notes, organized into two columns.

Aliaxis Deutschland GmbH
Steinzeugstraße 50
68229 Mannheim, Germany
T: +49 621 486-2238
info.de@alixis.com
www.alixis.de/en

