

FRIALEN® SAFETY FITTINGS

UAN UNIVERSAL ADAPTER HD-PE/BRASS WITH MALE THREAD

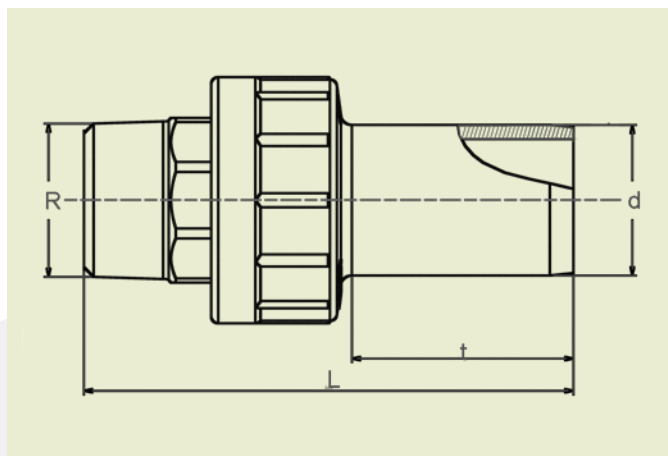

PE 100 SDR 11

Maximum working pressure 16 bar (water)/5 bar (gas)



d	R	Order Ref.	Stock-status	BX	PU	L	t	WS in mm	Weight kg/each
20	1/2"	616604	1	70	4200	94	41	22	0.100
25	3/4"	616605	1	60	2880	92	44	28	0.150
32	1"	616152	1	30	1800	104	47	35	0.240
40	1 1/4"	616153	1	20	960	121	56	44	0.400
50	1 1/2"	616154	1	16	900	123	57	50	0.520
63	1 1/2"	616610	3	9	540	136	63	50	0.620
63	2"	616155	1	9	540	140	63	62	0.730
75	2 1/2"	616612	3	14	336	155	70	77	1.200
90	3"	616613	3	6	180	172	78	90	1.600
110	4"	616614	3	4	120	200	87	115	2.900
125	4"	616664	3	4	120	200	92	115	2.950

Please observe the marking directly at the product, which is mandatory.

DVGW-Registration Nos.

■ DW-7511CR0155

■ DG-7521CR0172

V@Áia•È æ^Á@æá/Á æ^Á{ Á æ^ÁÁÖY ÎFG Á ÎÖY Î FÍ PÁU@Áia•Á æ^Á} Á^~^•dÁ

FRIALEN® SAFETY FITTINGS

UAN UNIVERSAL ADAPTER HD-PE/BRASS WITH MALE THREAD

Areas of Application

The FRIALEN Universal Adapter UAN serves to connect metal construction parts which have a screwed connection e.g. valves with an HD-PE connection pipe. Suitable for gas and water supply or for industrial applications. The version with PE spigot end allows for assembly regardless of location and the homogenous fusion connection with all suitable FRIALEN fittings (exception of FRIALONG- and FRIASTOPP-Long couplers).

The threaded joint is according DIN EN 10226-1.

Assembly Instructions

Usually the screw connection needs to be assembled first as assembly related torsion forces should not bear down on the connected PE pipe. The tightening forces must be introduced via the specially designed wrench area.

The fusion of the PE spigot end with a FRIALEN coupler takes place by using FRIALEN fusion process – leakproof and longitudinally strong.

The installation is according to the general installation instruction (see "Transition Fittings with threaded connection" in "Assembly Instructions" for "FRIALEN-Safety Fittings for house connections and distribution pipes up to d 225"). This involves removing the oxide layer and cleaning the pipe ends.

Good reasons for using the FRIALEN-Universal Adapter UAN:

- PE 100 spigot end – quality controlled
- Tested and quality controlled brass quality
- Assembly regardless of location, high degree of flexibility due to separate fusion of PE spigot end
- May be used with all FRIALEN fittings of identical dimensions (exception of FRIALONG- and FRIASTOPP-Long couplers)
- Universal combination option with the FRIALEN range
- HD-PE side with spigot end for processing without holding device, designed for FRIALEN couplers
- Pull-proof connection
- Brass side tightly connected with PE spigot end, safe from distortion
- Compact construction
- Additional barcode for tracing back the fitting (Traceability-Coding)
- Oxidic layer may be removed from PE spigot end using scraper tools