

FRIALEN® SAFETY FITTINGS

T T-PIECES

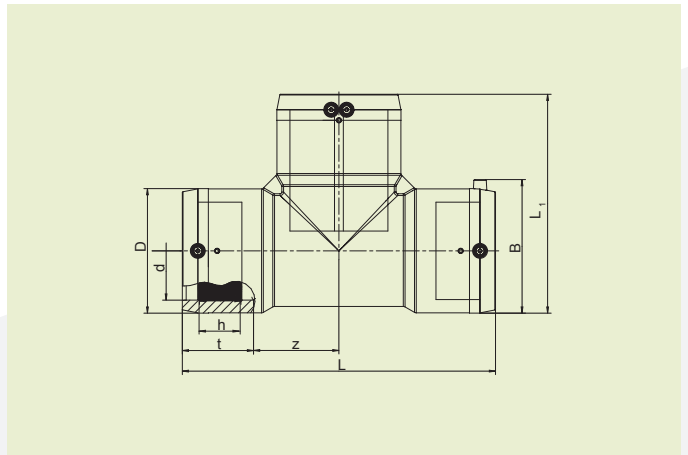

PE 100 SDR 11

Maximum working pressure 16 bar (water)/10 bar (gas)



d	Order Ref.	Stock-status	BX	PU	D	L	L ₁	t	z	h	B	Weight kg/each
75	612165	1	8	144	96	278	187	70	69	37	111	0,980
90	612166	1	10	80	117	305	211	79	73,5	44	129	1,650
110	612167	1	6	48	142	355	248	87	90,5	48	152	2,580
125	612168	1	5	40	160	384	272	87	105	44	168	3,520
160	615277	1	3	24	200	430	315	96	119	48	206	5,820
180	615691	1	2	16	228	480	354	103	137	62	229	7,900
200	616266	1	1	8	251	550	400	115	160	54	255	11,130
225	615692	1	1	8	280	580	430	118	172	63	281	13,900

FRIALEN-Safety Fittings can be fused to pipes of SDR stages 11 to 17.6. Other SDR-stages on request. Please observe the marking directly at the product, which is mandatory. DVGW-Registration No.: DV-8606AU2249

FRIALEN® SAFETY FITTINGS

T T-PIECES

Areas of Application

The FRIALEN T-pieces are used for equal pipe outlets of HD-PE pipelines.

Assembly Instructions

The fusion of the pipe ends with the FRIALEN T-piece takes place by FRIALEN electrofusion – leakproof and longitudinally strong.

The pipe ends are prepared according to the general installation instructions (see “Assembly Instructions for FRIALEN-Safety Fittings for house connections and distribution pipes up to d 225”). This involves removing the oxide skin and cleaning the pipe ends. The FRIALEN-T pieces have a straight passage fusible in one step. Therefore a total of only two fusions are necessary.

Good reasons for using the FRIALEN T-piece:

- Large coupler depth for ease of pipe guiding (no holding clamps required)
- Extra wide fusion zones
- Maximum stability through great wall thickness
- Cold zones at the front side and in the middle of the coupler
- Exposed heating coil for direct heat transmission to the pipe
- Small annular gap for build-up of optimum joining pressure in the fusion zone
- Touch proof electric contacts
- Durable batch marking
- Individually wrapped for dirt protection
- Additional barcode for tracing back the underground fitting (Traceability-Coding)