

FRIALEN® SAFETY FITTINGS

MUM TRANSITION FITTINGS HD-PE/GUNMETAL WITH FEMALE THREAD

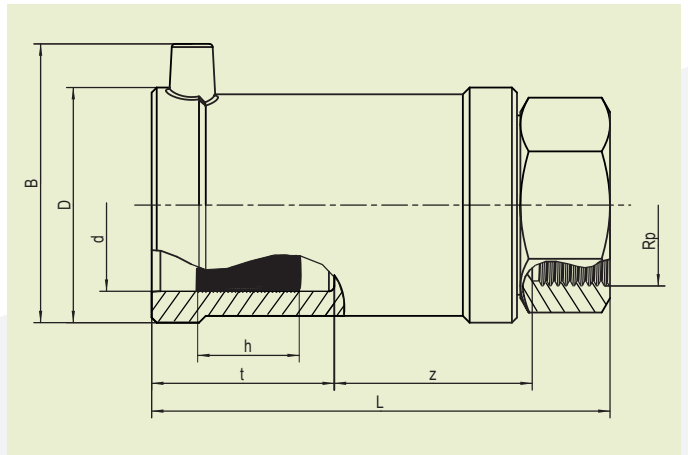
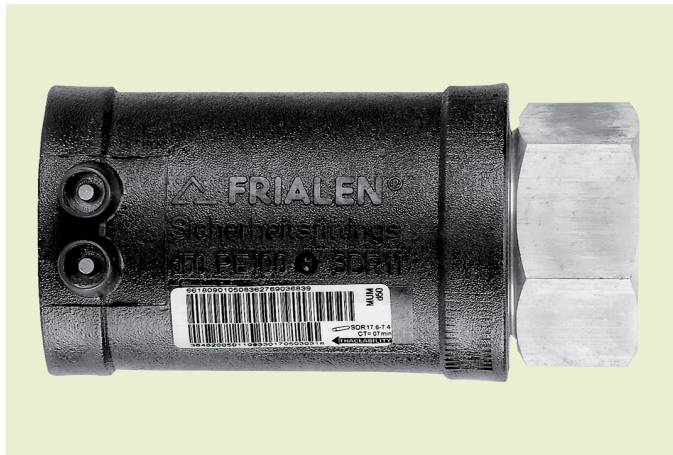

PE 100 SDR 11

Maximum working pressure 16 bar (water)



d	Rp	Order Ref.	Stock-status	BX	PU	D	L	t	z	h	B	Weight kg/each
32	1"	612595	1	20	1.080	47	112	42	49	24	61	0.360
40	1 1/4"	612596	1	20	800	58	121	46	53	30	70	0.520
50	1 1/2"	612692	1	15	600	70	136	53	60	30	80	0.650
63	1 1/2"	612708	1	10	300	84	141	53	61	35	94	1.230
63	2"	612693	1	10	400	84	141	53	61	35	94	1.050

Other thread sizes on request

FRIALEN safety fittings can be fused to pipes SDR11 - SDR 17.6. Minimum wall thickness $s_{min} \geq 3$ mm. Other SDR-stages on request. Please observe the marking directly at the product, which is mandatory. DVGW-Registration No. DV-7501AU2256

FRIALEN® SAFETY FITTINGS

MUM TRANSITION FITTINGS HD-PE/GUNMETAL WITH FEMALE THREAD

Areas of Application

FRIALEN-Transition Fittings MUM are threaded joints as an adaptor from a metal pipe with external thread to a HD-PE pipe. Joint on the part of HD-PE by FRIALEN-Coupler.

Assembly Instructions

The threaded component must be held with a spanner to prevent it twisting in the HD-PE component. The fusion of the HD-PE side takes place by FRIALEN-fusing – leakproof and longitudinally strong.

The installation of the gunmetal and the HD-PE side has to be prepared according to the general installation instructions (see "Transition Fittings with threaded connection" in "Assembly Instructions" for "FRIALEN-Safety Fittings for house connections and distribution pipes up to d 225"). This involves removing the oxide skin and cleaning the pipe ends.

Good reasons for using the FRIALEN-Transition Fittings MUM:

- Compact construction
- HD-PE side with exposed heating element for optimal heat transfer
- Cold zones at the end to prevent the flow of molten material
- No holding clamps required
- Large insertion depth, extra wide fusion zones
- Gunmetal end permanently anchored in the HD-PE and will not distort
- Self sealing patented sealing geometry without elastomer seal
- Additional barcode for tracing back the fitting (Traceability-Coding)