

FRIALEN® SAFETY FITTINGS

KHW BALL VALVES IN HD-PE SUITABLE FOR DRINKING WATER, 1/4-TURN, FULL PORT PASSAGE

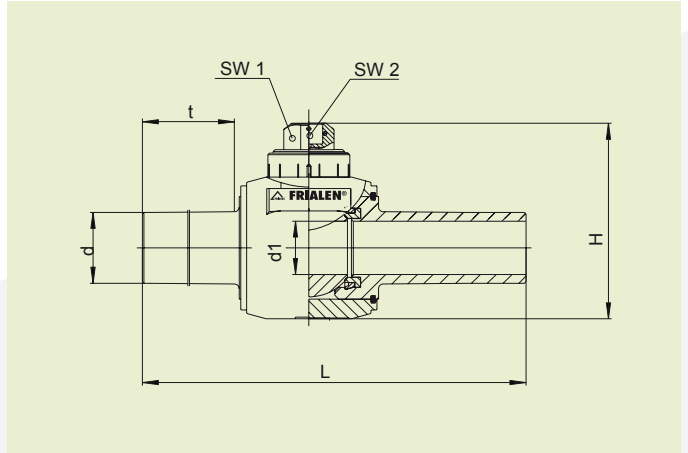

PE 100 SDR 11

Maximum working pressure 16 bar (water)



d	d ₁	Order Ref.	Stock-status	BX	PU	L	t	SW ₁	SW ₂	H	Weight kg/each
32	34	616656	1	1	100	324	108	50 x 50	20	156	0.770
40	34	616657	1	1	100	324	108	50 x 50	20	156	0.800
50	43	616658 ①	1	1	50	405	129	50 x 50	25	193	2.240
63	51	616659	1	1	50	410	134	50 x 50	25	206	2.420

① Please choose the suitable installation kit d 63 - d 225

FRIALEN-Safety Fittings can be fused to pipes of SDR-stages 11 to 17.6. Minimum wall thickness $s_{min} \geq 3$ mm. Other SDR-stages on request. Please observe the marking directly at the product, which is mandatory.

DVGW-Registration No.: DW-6210CQ0059

BS INSTALLATION KITS FOR BALL VALVES AND TAPPING BALL VALVES (STANDARD AND TOP-LOADING)

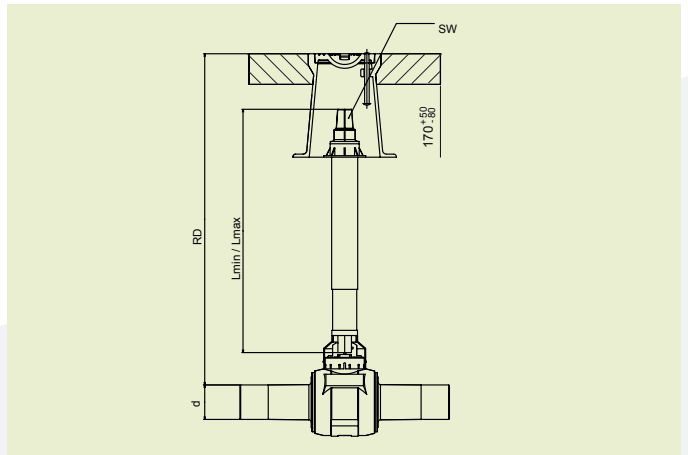

d	RD in m	Order Ref.	Stock-status	BX	PU	Lmin	Lmax	SW ₁	WS in mm	Weight kg/each
20-50	0,45-0,70	615741 ①	1	1	42	398	543	30	30	1.800
20-50	0,60-1,00	615957 ①	1	1	42	548	843	14	14	2.700
20-50	0,60-1,00	615328 ①	1	1	42	490	785	30	30	2.000
20-50	1,00-1,50	616466 ①	1	1	42	759	1303	14	14	3.400
20-50	1,00-1,50	615330 ①	1	1	42	799	1343	30	30	3.400
20-50	1,20-2,00	616068 ①	1	1	42	991	1785	14	14	3.450
20-50	1,20-2,00	615329 ①	1	1	42	1049	1843	30	30	3.650
63-225	0,60-1,00	615958	1	1	42	537	812	14	14	2.050
63-225	0,60-1,00	615310	1	1	42	490	785	30	30	3.050
63-225	1,00-1,50	616467	1	1	42	746	1272	14	14	4.150
63-225	1,00-1,50	615331	1	1	42	786	1312	30	30	4.150
63-225	1,20-2,00	616069	1	1	42	980	1754	14	14	3.600
63-225	1,20-2,00	615311	1	1	42	1038	1812	30	30	5.250

① Solid fit of the pipe sleeve socket due to the covered housing design.

Key width SW₁ 14 mm for use as house connection fitting

Other length on request.

For full-port passage ball valve KH d50 select version BS d63-225

FRIALEN® SAFETY FITTINGS

KHW BALL VALVES IN HD-PE SUITABLE FOR DRINKING WATER, 1/4-TURN, FULL PORT PASSAGE

Areas of Application

The FRIALEN-Ball Valve KHW with NBR-sealing with drinking water approval is suitable for shutting off sections of the main and also for isolating house connection pipes. The Ball Valve KHW can be applied in pipe systems for water supply, for compressed sewage, mineral and sea water pipes. Further media on request.

The passage of the valve (d1) corresponds approx. with the internal diameter of the pipe socket SDR without constriction.

The Ball Valve KHW is opened and closed by a 1/4-turn with the installation kit BS. The installation kit BS allows the operation from the street cap and is optimal adapted to the FRIALEN-Ball Valve KHW. For further information see this data sheet page 2. or data sheet installation kit BS No. 22/00.

Assembly Instructions

The FRIALEN-Ball Valve KHW is connected to the pipe by using Couplers, Elbows or T-Pieces fused to its ends. The connection with HD-PE pipes takes place by FRIALEN-fusing – leakproof and longitudinally strong.

The spigot ends to be fused are prepared according to the general installation instructions (see “Assembly Instructions” for “FRIALEN-Safety Fittings for house connections and distribution pipes up to d 225”). This involves removing the oxide layer and cleaning the pipe ends.

Before fusion the FRIALEN-Ball Valve KHW must be lined up to suit the type of actuation intended, in order to ensure that the installation kit BS will be placed correctly.

Good reasons for using the FRIALEN-Ball Valve KHW:

- The FRIALEN-Ball Valve provides a completely fused HD-PE pipe network, without transitions to other materials or flange connections
- Another step towards a pure PE-pipe system
- Optimum hydraulics due to pipe identical passage and contour providing ease of flow
- Good testability due to lack of constriction of internal diameter
- Floating ball, axial seals in the ball axle and combination of ball guidance and ball seal in one part compensate for bending defects
- No deposits on internal areas, resistant to chemical and electrical reactions
- No corrosion proofing required
- Optimum hydraulics due to pipe identical passage and contour providing ease of flow, optimum flow speed
- Low activating element, low weight
- Extra long spigot ends dimensioned for two fusion operations
- Actuating of the KHW with the telescopic installation kit BS
- Additional barcode for tracing back the underground fitting (Traceability-Coding)