

## FRIALEN® SAFETY FITTINGS

### FLT FLANGE T-PIECES

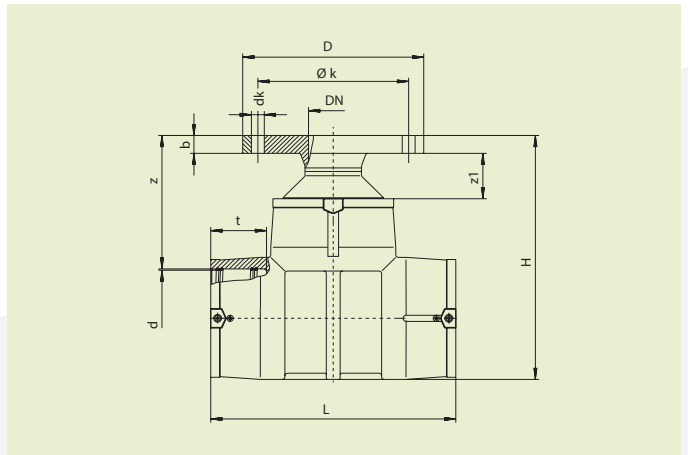

#### PE 100 SDR 11

Maximum working pressure 16 bar (water)



d/DN	Order Ref.	Stock-status	BX	PU	D	L	t	z	z <sub>1</sub>	d <sub>k</sub>	Ø k	H	Holes for screw	Weight kg/each
110/80	615590	1	4	32	204	355	87	190	42	17	160	316	8	4.920
125/80	615591	1	3	24	204	384	87	190	45	17	160	343	8	5.480
160/80	615592	1	2	16	204	430	96	210	50	17	160	390	8	8.050
180/80	615910	1	1	8	204	480	103	210		17	160	416	8	10.000

#### PE 100 SDR 17

Maximum working pressure 10 bar (water)



d/DN	Order Ref.	Stock-status	BX	PU	D	L	t	z	d <sub>k</sub>	Ø k	H	Holes for screw	Weight kg/each
225/80	616031	1	2	4	204	580	118	210	17	160	465	8	15.420

FRIALEN-Safety Fittings can be fused to pipes of SDR stages 11 to 17.6. Other SDR-stages on request. Please observe the marking directly at the product, which is mandatory. DVGW-Registration No.: DV-8606AU2249

## FRIALEN® SAFETY FITTINGS

### FLT FLANGE T-PIECES

#### Areas of Application

The FRIALEN Flange T-Piece is used for the transition between HD-PE pipes to pipes or valves made from metal. The main area of application of the FRIALEN Flange T-Piece is the hydrant connection. For a branch line in DN 80 you can flange directly a shut-off valve. Other nominal diameters can be also realised with the FRIALEN T-Piece<sup>1)</sup> in combination with FRIALEN flange reducer FLR respectively if the nominal diameter is equal with the FRIALEN Full faced flange EFL<sup>2)</sup>.

#### Assembly Instructions

The Flange T-Piece is installed only in pressure-free condition. Please refer to the FRIALEN-Assembly Instructions with regard to the preparations of the T-Piece in the direction of the passage opening with HD-PE pipes (marking of insertion depth, removing oxide skin, cleaning, etc.) for FRIALEN fusion.

Flange connection measurements correspond to DIN EN 1092-1.

Supplementary washers are necessary.

All standard profile or flat gaskets can be used. Please observe screw torque specifications as indicated by the gasket manufacturer. We recommend G-ST gaskets.

<sup>1)</sup> see Data Sheet No. 10

<sup>2)</sup> see Data Sheet No. 46

#### Good reasons for using the FRIALEN Flange T-Piece FLT:

- Compact part in HD-PE for direct connection to flanged valves and hydrants
- Factory made combination made from FRIALEN T-Piece, Reducer and Weld in flange (fixed flange)
- Optional installation position (upright or horizontal position)
- No inner fusion ridge on the fused seam of the reducer
- No "cold-flow characteristics" at the flange due to constructive design
- Short dimensions with regard to height and length
- Particularly economical solution
- T-Piece with exposed heating coils for optimal heat transfer, large insertion depth, wide fusion zones plus cold zones at the end and in the middle to prevent the flow of molten material
- Additional barcode for tracing back the underground fitting (Traceability-Coding)