

## FRIALEN® Installation kits for Pressure Tapping Valves EBS

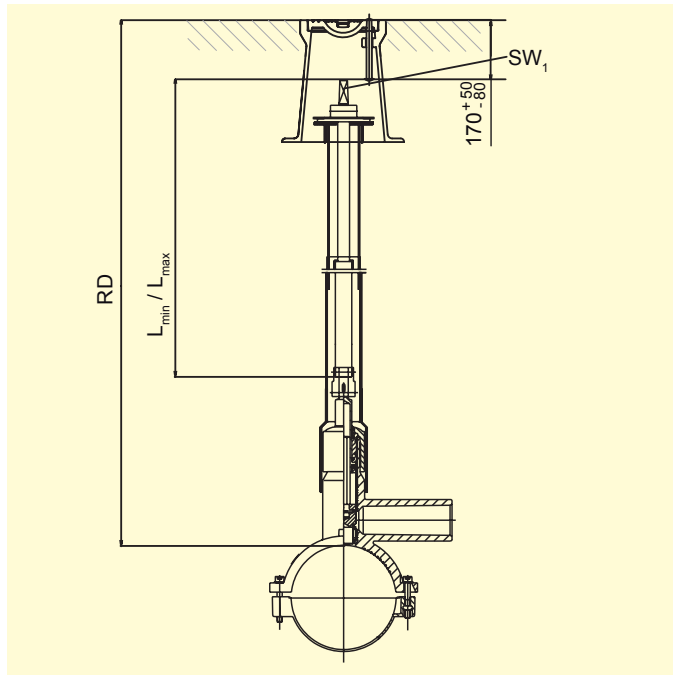

| RD in m  | Order Ref.    | Stock-status | BX | PU | L <sub>min</sub> | L <sub>max</sub> | SW1 | Weight kg/each |
|----------|---------------|--------------|----|----|------------------|------------------|-----|----------------|
| 0,45-0,7 | <b>615866</b> | 1            | 1  | 42 | 260              | 370              | 14  | 1,740          |
| 0,7-1,0  | <b>615867</b> | 1            | 1  | 42 | 410              | 670              | 14  | 2,150          |
| 0,9-1,3  | <b>615335</b> | 1            | 1  | 42 | 525              | 980              | 14  | 2,650          |
| 1,2-1,8  | <b>615325</b> | 1            | 1  | 42 | 860              | 1570             | 14  | 3,600          |

Other length on request  
 Only applies when using FRIALEN Pressure Tapping Valves

## FRIALEN® Installation kits for Pressure Tapping Valves EBS

### Areas of Application

Telescopic actuating linkage for operation of the FRIALEN-DAV from the street cap.

### Assembly Instructions

Dimension RD valid for DAV  $d_1 = 90-125$ . For DAV  $d_1 < 90$  please deduct -50 mm and for  $d_1 > 125$  please add +50 mm (also see DAV dimension L).

Ten good reasons for using the FRIALEN-Installation kit EBS:

- Stepless adjustment in the stated range ( $L_{\min}/L_{\max}$ ) without the use of tools
- Self supporting in any extended position
- Safe from pulling out
- Assembly without tools
- Corrosion proof
- Telescopic installation kit can be extended even once it has been installed and filled
- Constructive tuning of transferable torque to FRIALEN-DAV
- Break-proof dome coupler
- Stainless steel connecting pins
- Parts of the protective pipe are fully welded together

**For further information, please call our customer service staff and specialist advisers.**

FRIATEC Aktiengesellschaft · Technical Plastics Division  
 P.O.B. 71 02 61 · D-68222 Mannheim  
 Telephone +49 621 486-1431 · Telefax +49 621 479196  
 www.friatec.com · E-Mail: info-frialen@friatec.de

Please find our datasheets for downloading on the internet at [www.friatec.com](http://www.friatec.com)