



# Operating instructions

Chain Peeler

for the use of PE - and PP - pipes

d 800 - 1200 mm / 32 - 48 "IPS / 30 - 42 "DIPS

Doc.-No. 2605



# Table of contents

<b>1.</b>	<b>Range of fitting dimensions .....</b>	<b>2</b>
<b>2.</b>	<b>Safety .....</b>	<b>4</b>
<b>2.1</b>	<b>General safety guidelines for tools.....</b>	<b>4</b>
<b>2.2</b>	<b>Specific safety guidelines for the Chain Peeler.....</b>	<b>5</b>
<b>2.3</b>	<b>Explanation of symbols .....</b>	<b>5</b>
2.3.1	General symbols .....	5
2.3.2	Mandatory symbols .....	5
2.3.3	Prohibition symbols .....	5
2.3.4	Warning symbols.....	5
<b>3.</b>	<b>Introduction.....</b>	<b>6</b>
<b>3.1</b>	<b>Scope of application .....</b>	<b>6</b>
<b>3.2</b>	<b>Maintenance and service .....</b>	<b>6</b>
<b>3.3</b>	<b>Handling and maintenance.....</b>	<b>6</b>
<b>3.4</b>	<b>Disposal .....</b>	<b>6</b>
<b>4.</b>	<b>Scope of delivery .....</b>	<b>7</b>
<b>5.</b>	<b>Technical data.....</b>	<b>8</b>
<b>6.</b>	<b>Overview and spare parts .....</b>	<b>9</b>
<b>6.1</b>	<b>Special features.....</b>	<b>9</b>
<b>7.</b>	<b>Composition of the Chain Peeler .....</b>	<b>10</b>
<b>7.1</b>	<b>Assembly of the Chain Peeler .....</b>	<b>11</b>
<b>8.</b>	<b>Peeling.....</b>	<b>11</b>
<b>8.1</b>	<b>Preparation: Cleaning and marking.....</b>	<b>11</b>
<b>8.2</b>	<b>Installing and tensioning the Chain Peeler .....</b>	<b>12</b>
8.2.1	Application 1: Peeling pipe ends .....	12
8.2.2	Application 2: Peeling the pipe for a saddle .....	13
8.2.3	Note the indicators .....	14
<b>8.3</b>	<b>Peeling the pipe.....</b>	<b>15</b>
<b>9.</b>	<b>Removing the Chain Peeler .....</b>	<b>16</b>
<b>9.1</b>	<b>Additional notes .....</b>	<b>16</b>
<b>10.</b>	<b>Adjusting the feed .....</b>	<b>17</b>
<b>10.1</b>	<b>Increase the feed (widen peel width).....</b>	<b>17</b>
<b>10.2</b>	<b>Reducing the feed (reducing the peel width).....</b>	<b>18</b>
<b>11.</b>	<b>Changing the peeler blade.....</b>	<b>19</b>

## 2. Safety

The basic condition for safely handling and a hassle-free operation of the product is the knowledge about the fundamental safety guidelines and safety regulations. This instruction manual contains important information on how to handle the tool safely. Everyone working with this equipment shall read and understand these instructions. These instructions shall be read and implemented in accordance with the relevant standards, workplace health and safety legislation, installation instructions, Codes of Practice and technical connection guideline in force in your country.

### 2.1 General safety guidelines for tools

a) Read and make sure you understand all safety guidelines and instructions. Failure to follow the safety guidelines and instructions can lead to electric shock, fire and/or serious injury.

b) Keep these safety guidelines and instructions for future use.

#### 2) Safety in the work area

a) Keep your work area clean and well lit. Working in cluttered or dark areas can easily lead to accidents. Prevent the tool from unintentional movement or dropping and assume a secure foothold.

#### 3) Personal safety

a) Stay alert! Watch what you are doing and use common sense when operating a tool.

b) Use personal protective equipment and always wear eye protection. The use of protective equipment such as a dust mask, non-skid safety shoes, a hard hat or hearing protection, depending on the tool and its use will reduce personal injuries.

c) Wear appropriate clothing. Do not wear loose clothing or jewellery. Keep your hair, clothing and gloves away from moving parts. Loose clothes, jewellery or long hair can get caught by moving parts.

#### 4) Tool usage and care

a) Keep cutting tools sharp and clean. Properly maintained cutting tools with sharp and clean blades do not get stuck as easily and are easier to handle during operation.

b) The blade is subject to wear. When not in use, always keep the Chain Peeler clean and dry in the suitcase.

c) Keep your tools clean. Follow the servicing instructions and the instructions for changing the tools. Keep oil and grease away from the handles.

d) Care for your tools. Check for misalignment or binding of moving parts, breakage of parts and any other condition that may affect the operation of the tools. If damaged, have the tool repaired before use. Many accidents are caused by poorly maintained tools.

e) Use the tool, accessories etc. in accordance with these instructions. Take the working conditions and the work to be performed into account. The use of the tool for applications differing from the application scope could result in a hazardous situation.

f) The thickness of the peeling must be checked with a suitable measuring instrument on a regular basis.

#### 5) Service

a) Have your tool repaired only by a qualified technician with identical replacement parts. This will ensure that the safety of the tool is maintained.

## 2.2 Specific safety guidelines for the Chain Peeler

### 1) Personal safety

- a) The operator must have a safe foothold. Working overhead in areas not completely visible (e.g. under a pipe) is prohibited.
- b) Pipes and other workpieces must be firmly clamped or fixed. Poorly clamped or fixed workpieces may hurt you or affect your safe foothold.
- c) The blade is very sharp. This poses a risk of injury. Do not touch the blade.

## 2.3 Explanation of symbols

This instruction manual can make use of the following symbols:

### 2.3.1 General symbols



**This symbol indicates a general advice.**

These advices describe recommended courses of action to enable the user to perform steps quicker and safer. The symbol can also underline certain required precondition or mean that the user must follow certain mandatory steps.

### 2.3.2 Mandatory symbols



**Observe the instructions!**

Read the provided documentation thoroughly to prevent applications errors and to work safer and according to the scope of application with the respective product. All users of the product must thoroughly read and understand the provided documentation prior to use.

**Reading the documentation thoroughly and completely helps preventing accidents due to improper use and eases the work with the product.**

### 2.3.3 Prohibition symbols



**General prohibition symbol!**

There is a high risk of injury. Observe the detailed description of the prohibition.

**Failure to comply with this prohibition can lead to injury or damage to devices, machines or tools.**

### 2.3.4 Warning symbols



**General warning symbol!**

This symbol warns of a potentially dangerous situation.

**Failure to comply with the warning and advice can lead to injury or damage to goods.**



**Warning: Sharp elements!**

This symbol warns of a potential risk of injury due to pointy and/or sharp items like needles or blades.

**Failure to comply with the warning and advice can lead to stabbing or cutting injuries to the hands or other body parts.**

### 3. Introduction

#### 3.1 Scope of application

The Chain Peelers 800-1200 mm, 800-1400 mm and 800-1600 mm are solely meant for the removal of the oxide layer on polyethylene pipes as preparation for electrofusion (EF). Additionally they are approved for usage on polypropylene (PP) and cross-linked polyethylene (PE-X) pipes.

The peeler chains can universally be used to peel pipe ends (for welding fittings) and to peel spots on pipes (for welding saddles).



##### **Intended use**

The product may not be used for any purposes other than those mentioned. Modifying the tool without consulting the manufacturer is forbidden and shall be considered as improper use.

**The manufacturer cannot be held liable if the chain peeler was used improperly and outside of the scope of application!**

#### 3.2 Maintenance and service

Should the tool fail despite the great care taken in manufacturing and testing it, the necessary repairs should only be carried out by an after-sales service centre authorised by the manufacturer.

Please note that the product is a technically demanding machine for field application. In accordance to the applicable standards the tool is subject to periodical maintenance. The maintenance interval is 12 months, with heavy use shorter intervals are recommended.

During maintenance, the tool will be upgraded to the current technical standard of our devices and you get a 3-month guarantee on function for the maintained tool.

The maintenance and the related checks are important for your safety and the continuous working reliability and safety of the product. Therefore, the maintenance and all necessary repairs, have to be carried out by the manufacturer or an authorised service point.

For further information about our after-sales service centres please contact:

**PF-Schweißtechnologie GmbH**  
**Karl-Bröger-Str. 10**  
**DE-36304 Alsfeld**  
**Germany**

**Tel.: +49-6631-9652-0**  
**Fax: +49-6631-9652-52**  
**E-Mail: info@pfs-gmbh.com**  
**Web: www.pfs-gmbh.com**

In all correspondence, please provide the serial number (S/N) as shown on the type plate of the tool.

#### 3.3 Handling and maintenance

To achieve an optimum work results the tool has to be handled with care and maintained frequently. Pollution by sand and dirt has to be avoided or, if necessary, removed with a soft cloth or a Q-tip.

#### 3.4 Disposal

The Chain Peeler must be disposed of in an environment-friendly way sorted by materials.

## 4. Scope of delivery

Code	Chain Peeler 800-1200 mm	Extension 1400 mm for Chain Peeler 800-1200 mm	Chain Peeler 800-1400 mm	Extension 1200-1600 mm for Chain Peeler 800-1200 mm	Chain Peeler 800-1600 mm
	4_4200_012	4_4200_012/2	4_4200_012/1	4_4200_012/3	4_4200_012/4
Instruction manual					
DEZ72					
Assembly plan	1 x		1 x		1 x
Tensioning and peeling unit	1 x		2_4200_011		1 x
Link piece 150 mm	7 x	2_2400_005/2	2_2400_005/2	1 x	2_2400_005/2
Link piece 200 mm	5 x		2_2400_006		2_2400_006
Link piece 250 mm					
Roller wagon 200 mm	7 x	2_4200_001/1	2_2400_008/1	1 x	2_2400_008/1
Hex key SW4/SW2.5	1 x		2_4200_001/1	3 x	2_4200_001/1
Hex key SW2.5 (long)	1 x		1_2904_003		1_2904_003
Spare blade M03, wide	1 x		2_2904_004		2_2904_004
Plastic suitcase	1 x		2_4201_003		2_4201_003
		1 x	1_2800_035	1 x	1_2800_035

The given technical information is valid for the standard setup of the tool. Depending on the ordered setup there may be variations.

## 5. Technical data

General		Chain Peeler 800-1200 mm	Extension 1400 mm for Chain Peeler 800-1200 mm	Chain Peeler 800-1400 mm	Extension 1400-1600 mm for Chain Peeler 800-1200 mm	Chain Peeler 800-1600 mm
For pipe dimensions	[mm]	800-1200	1400	800-1400	1200-1600	800-1600
For pipe dimensions	IPS	32-48	54	32-54	48-63	32-63
For pipe dimensions	DIPS	30-42	48	30-48	48-60	30-60
Code		4_4200_012	4_4200_012/2	4_4200_012/1	4_4200_012/3	4_4200_012/4
Suitable for pipes made of		PE, PE-HD, PE-X				
Peeling depth	[mm]	0.3 (0.25 to 0.35)				
Dimensions, weights and packaging						
Product dimensions L×W×H	[mm]	Abhängig von Rohrdimension×100×85	Abhängig von Rohrdimension×100×85	Abhängig von Rohrdimension×100×85	Abhängig von Rohrdimension×100×85	Abhängig von Rohrdimension×100×85
Product weight	[kg]	9.5	1.6	10.5	2.1	11
Packaging dimensions L×W×H	[mm]	580×470×265	400×110×290	580×470×265	400×110×290	580×470×265
Packaging material		Plastic				
Packaging type		Suitcase				
Packaging weight	[kg]	5	0.8	5	0.8	5
Transport weight	[kg]	14.5	2.5	15.5	3	16

The given technical information is valid for the standard setup of the tool. Depending on the ordered setup there may be variations.

## 6. Overview and spare parts

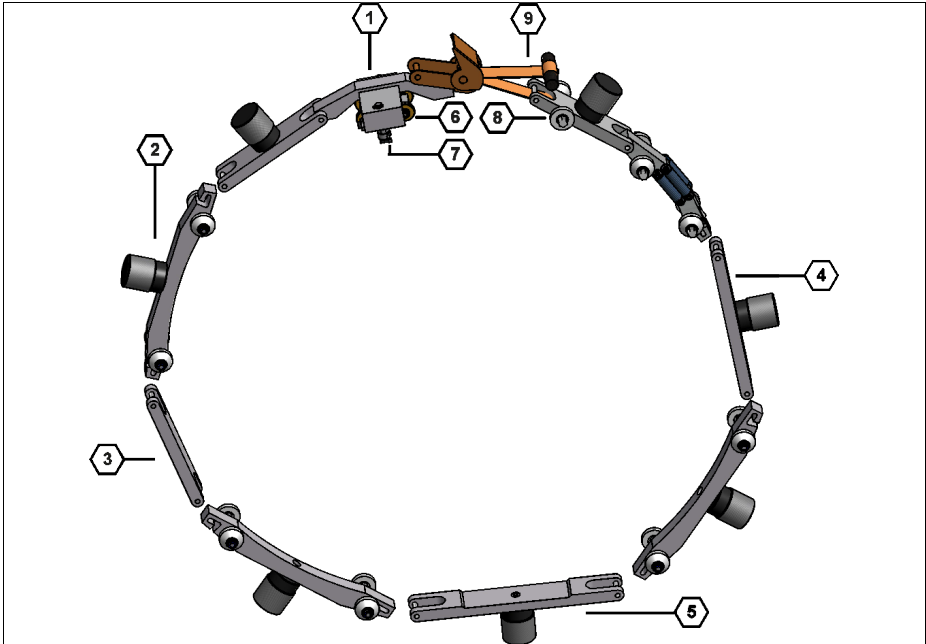

Object in graphic	Description	Code
1	Tensioning and peeling unit	2_4200_011
2	Roller wagon 200 mm	2_4200_001/1
3	Link piece 150 mm	2_2400_005
4	Link piece 200 mm	2_2400_006
5	Link piece 250 mm	2_2400_008/1
6	Feed roller, large	2_2502_006/2
7	Peeler blade, large	2_4201_003
8	Running wheel	2_2502_005/3
9	Ratchet strap 25 mm incl. handle	2_2300_007
Not depicted	Hex key screwdriver	1_2904_003
Not depicted	Hex screwdriver (long)	1_2904_004

### 6.1 Special features

- Quick tensioning and adjustment to various pipe dimensions due to individual elements.
- Ovality compensation by spring action.
- Tiltable blade as well as tiltable blade wagon for optimum guidance of the peeler blade on uneven or dented pipe surfaces.

## 7. Composition of the Chain Peeler



### **Danger of cutting injuries by peeling blade!**

The blade is very sharp! Handling the spare blades involves a high risk of injury.

**Always wear cut-proof gloves as soon as you handle the peeling blades.**

Depending on the dimension of the pipe a different number of roller wagons and link pieces must be used. A complete Chain Peeler consists of a tensioning and peeling unit and, depending on the ordered version (plus optional extension), a different number of roller wagons with link pieces. The table below gives an overview of the composition for different pipe diameters.

Pipe dimension			Tensioning and peeling unit	Roller wagon 200 mm	Link piece 150 mm	Link piece 200 mm	Link piece 250 mm
mm	IPS	DIPS					
800	32"	30"	1	4	-	4	-
	34"		1	5	5	-	-
900	36"		1	5	2	3	-
		36"	1	5	-	5	-
1000			1	6	5	1	-
	42"		1	6	2	4	-
		42"	1	7	7	-	-
1200	48"		1	7	3	4	-
	52"	48"	1	8	6	2	-
	54"		1	8	2	5	1
1400			1	9	8	1	-
		54"	1	9	6	2	1
		60"	1	10	7	3	-
1600	63"		1	10	6	3	1

## 7.1 Assembly of the Chain Peeler

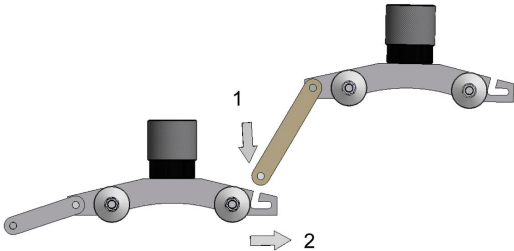
Step	Action
<p><b>1</b></p> <p><b>Connecting the roller wagons</b></p> <p>1.1</p>	<p>Like shown in the picture, the single roller wagons with link pieces can be easily attached to one another. Attaching the individual elements is only possible when inserting them at a certain angle. This prevents an unintentional falling apart of the assembled chain.</p> 

## 8. Peeling

### 8.1 Preparation: Cleaning and marking

Step	Action
<p><b>1</b></p> <p><b>Cleaning the pipe</b></p> <p>1.1</p>	<p>Use a clean cloth free of dirt and grease to remove mud, sand and dirt from the surface you want to peel. If necessary additionally use certified pipe cleaner.</p>
<p><b>2</b></p> <p><b>Mark the area you want to peel</b></p> <p>2.1</p>	<p>Mark the stab depth of the fitting resp. the area of contact of the saddle according to the processing guidelines of the fitting manufacturer with a certified marker. The area to be peeled should be marked with wave-like markings.</p>

## 8.2 Installing and tensioning the Chain Peeler



### Attention!

- The Chain Peeler always runs ahead of the peeling blade.
- When peeling pipe ends which have a smaller diameter than the rest of the pipe it can be necessary to loosen the Chain Peeler and tighten it again. Due to the increasing diameter of the pipe the tensioning of the Chain Peeler is sufficient for the smaller pipe end section but it can be too tight when you leave the smaller pipe section during the process of peeling.
- This results in a higher force needed for peeling. When you notice this loosen the Chain Peeler and re-tighten it.

### 8.2.1 Application 1: Peeling pipe ends

Step	Action
<b>1</b>	<b>Fully open the strap ratchet</b>
1.1	Fully open the strap ratchet to unlock the slotted spindle. The black rod prevents the strap from slipping out of the ratchet.
<b>2</b>	<b>Put the Chain Peeler around the pipe</b>
2.1	Put the assembled Chain Peeler around the pipe. If that is not possible, connect the ends of the Chain Peeler after having put it around the pipe.
<b>3</b>	<b>Align the peeling blade</b>
3.1	Put the assembled Chain Peeler around the pipe. The blade must rest with about $\frac{1}{2}$ - $\frac{3}{4}$ of its width on the pipe end.
<b>3</b>	<b>Tensioning the chain</b>
3.1	Pull the strap using the black rod, so that the chain is tightens around the pipe. Make sure that the chain is perpendicular to the pipe.
3.1	Pull the black rod tight with one hand and hold/support it, using the black knob as support. Use the ratchet to tighten the Chain Peeler around the pipe.

### 8.2.2 Application 2: Peeling the pipe for a saddle

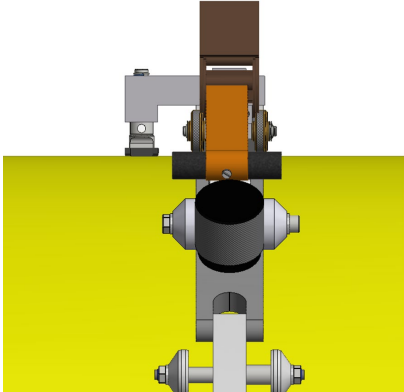
Step	Action
<p><b>1 Fully open the strap ratchet</b></p> <p>1.1 Fully open the strap ratchet to unlock the slotted spindle. The black rod prevents the strap from slipping out of the ratchet.</p>	
<p><b>2 Put the Chain Peeler around the pipe</b></p> <p>2.1 Put the assembled Chain Peeler around the pipe. If that is not possible, connect the ends of the Chain Peeler after having put it around the pipe.</p>	
<p><b>3 Align the peeling blade</b></p> <p>3.1 Put the Chain Peeler at the appropriate point around the pipe and close the chain. The blade should be set on the middle of the outer limit of the marking on the area of contact.</p>	
<p><b>3 Tensioning the chain</b></p> <p>3.1 Pull the strap using the black rod, so that the chain is tightens around the pipe. Make sure that the chain is perpendicular to the pipe.</p> <p>3.1 Pull the black rod tight with one hand and hold/support it, using the black knob as support. Use the ratchet to tighten the Chain Peeler around the pipe.</p>	

### 8.2.3 Note the indicators

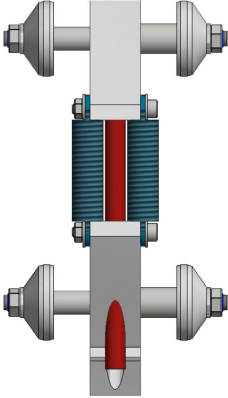
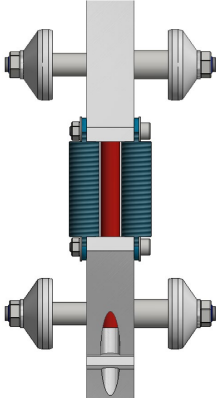
Step	Action
<p><b>1</b></p> <p><b>Indicator on the spring wagon</b></p> <p>1.1</p>	<p>An indicator pin is located on the spring wagon. The Chain Peeler is tightened sufficiently when the indicator pin is still visible.</p> <div style="display: flex; justify-content: space-around; align-items: center;"> <div style="text-align: center;">  <p><b>Spring wagon not tightened</b></p> </div> <div style="text-align: center;">  <p><b>Spring wagon tightened</b></p> </div> </div>
<div style="border: 2px solid black; padding: 10px;"> <p><b>Note</b></p> <p>The indicator pin gives you information about the tension in the Chain Peeler. Depending on the pipe dimension, it can become necessary to apply lesser or more tension so the indicator is retracted or protruded a little more.</p> <p>Excessive tightening may damage the Chain Peeler. If you tension the Chain Peeler too much, the indicator pin can slip from its guidance bore and become lost.</p> </div>	

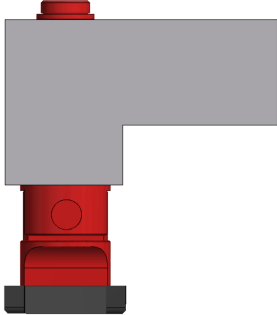
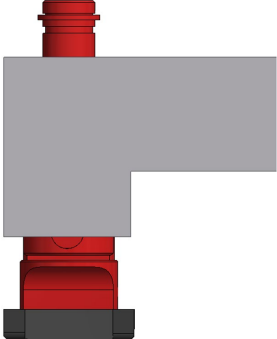
Step	Action
<p><b>2</b></p> <p>2.1</p>	<p><b>Indicator on the blade holder</b></p> <p>The blade holder also features an indicator pin. When the tensioning force is increased it will protrude on the upper side.</p> <div style="display: flex; justify-content: space-around; align-items: center;"> <div style="text-align: center;">  <p><b>Blade holder free of tension</b></p> </div> <div style="text-align: center;">  <p><b>Blade holder under tension</b></p> </div> </div>



**Note**

Always make sure that the blade holder is not fully compressed. Only then the spring in the blade holder will push the peeler blade forcefully enough against the pipe surface to peel flat spots.

### 8.3 Peeling the pipe

Step	Action
<p><b>1</b></p> <p>1.1</p>	<p><b>Clamping and fixing the pipe</b></p> <p>Fix or clamp the pipe before you begin peeling it to improve the peeling result and prevent accidents.</p>
<p><b>2</b></p> <p>2.1</p> <p>2.2</p>	<p><b>Beginning the peeling procedure</b></p> <p>When you are finished with tensioning, after having checked both indicator pins while tensioning, you can begin with the peeling procedure.</p> <p>Begin peeling by pulling the Chain Peeler around the pipe. The Chain Peeler has its own feed. Do not tilt the chain. Your position should ideally be 90° to the pipe so that no axial forces influence the set feed of the tool.</p>



When peeling position yourself directly in front of the Chain Peeler and pull on the handles.

**If you stand to the side of the chain and pull it, a reliable and precise feed cannot be guaranteed.**

Step	Action
<b>3</b>	<b>Observe the peel width</b>
2.1	After the first rotation, check if the peel width measures about 2/3 max. of the blade width. If the peel width is larger or considerably smaller, the feed must be readjusted. See chapter 10 „Adjusting the feed“.
2.2	Pull the Chain Peeler around the pipe until the blade reaches the end of the marked area.



**Note**

In case of an insufficient peeling the feed has to be checked and readjusted or the blade has to be replaced. In consideration of the processing guidelines of the fitting manufacturer and the tolerances specified therein (max. gap between pipe and fitting) the pipe may be peeled a second time.

The peeling blades are subject to wear

Use only on cleaned pipe surfaces.

Keep the Chain Peeler clean and dry in the suitcase.

The thickness of the peel must be regularly checked with a suitable measuring device.

## 9. Removing the Chain Peeler

Step	Action
<b>1</b>	<b>Releasing the tension</b>
1.1	To remove the Chain Peeler from the pipe the ratchet of the ratchet strap must be opened.
1.2	Do not use any extra tools to release the tension. Use the locking pawl on the strap ratchet to controllably release the tension.
<b>2</b>	<b>Removing the Chain Peeler</b>
2.1	Disconnect the Chain Peeler or take it off in one piece.
<b>3</b>	<b>Safely store the Chain Peeler</b>
3.1	Disassemble the Chain Peeler after using it and put its parts back into the transport container. This will keep the tool in a good condition.



**Note**

After removing the Chain Peeler from the pipe, always make sure that you have completely scraped the marked area.

### 9.1 Additional notes

- In case of an insufficient peeling result the blade has to be replaced.
- In consideration of the processing guidelines of the fitting manufacturer and the tolerances specified therein (max. gap between pipe and fitting) the pipe may be peeled a second time.
- The peeler blades are subject to wear
- Use only on cleaned pipe surfaces.
- When not in use, always keep the Chain Peeler clean and dry in the suitcase!
- The thickness of the peeling must be checked with a suitable measuring instrument on a regular basis.

## 10. Adjusting the feed

### 10.1 Increase the feed (widen peel width)

To increase the feed and the peel width, the feed wagon must be pivoted slightly more towards the non scraped area.



#### Note

The smaller the pipe dimension of the pipe to be peeled, the more feed is necessary to maintain a peel width of about 1/2 to 2/3 of the blade width.

Turn the adjustment screws only by 1/4 turn increments and afterwards peel for 2 or 3 rotations so that the altered feed setting can take effect.

Step	Action
<b>1</b>	<b>Screw out the right adjustment screw</b>
1.1	Turn the right adjustment screw (1) for 1/4 turn (counter-clockwise).
<b>2</b>	<b>Screw in the left adjustment screw</b>
2.1	Turn the left adjustment screw (2) for 1/4 turn (clockwise).
<b>3</b>	<b>Check the feed</b>
3.1	After the adjustment make sure that the feed wagon is fixed again so that it does not move. Check the altered feed setting by peeling further.

## 10.2 Reducing the feed (reducing the peel width)

To reduce the feed and the peel width, the feed wagon must be pivoted slightly more towards the already peeled area.



### Note

The bigger the pipe dimension of the pipe to be peeled, the less feed is necessary to maintain a peel width of about 1/2 to 2/3 of the blade width.

Turn the adjustment screws only by 1/4 turn increments and afterwards peel for 2 or 3 rotations so that the altered feed setting can take effect.

Step	Action
<b>1</b>	<b>Screw out the left adjustment screw</b>
1.1	Turn the left adjustment screw (1) for 1/4 turn (counter-clockwise).
<b>2</b>	<b>Screw in the right adjustment screw</b>
2.1	Turn the right adjustment screw (2) for 1/4 turn (clockwise).
<b>3</b>	<b>Check the feed</b>
3.1	After the adjustment make sure that the feed wagon is fixed again so that it does not move. Check the altered feed setting by peeling further.

# 11. Changing the peeler blade



**Attention!**

The blade is very sharp! Handling the spare blades involves a high risk of injury. Always wear cut-proof gloves as soon as you handle the peeling blades.

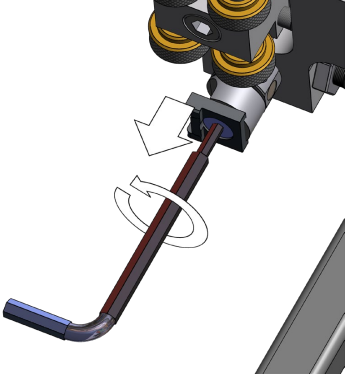
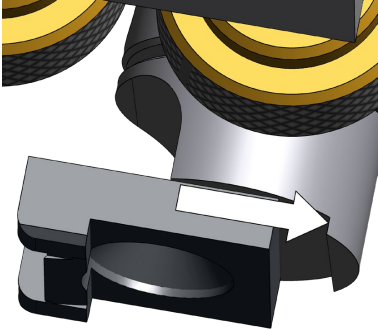
Step	Action
<p><b>1</b></p> <p><b>Loosen the screw</b></p> <p>1.1</p>	<p>Loosen the hexagon socket head screw (2.5 mm) that secures the peeler blade on the blade holder with the enclosed key and remove the old peeler blade.</p> 
<p><b>2</b></p> <p><b>Install new peeler blade</b></p> <p>2.1</p>	<p>Make sure that the peeler blade lies flat on the blade holder and that it touches the stop with its backside.</p> 

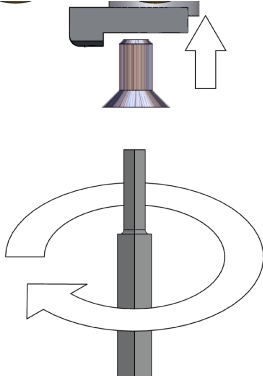
Step	Action
<p><b>3</b></p> <p>3.1</p>	<p><b>Fix the new peeler blade</b></p> <p>Hold the peeler blade in this position and screw the hexagon socket head screw (2.5 mm) in again with the enclosed key.</p> 



**Note**

The spare blades are incompatible with the pipe end peelers of PF-Schweisstechnologie GmbH, because these have a different edge.







**Aliaxis Deutschland GmbH**

Infrastructure

Steinzeugstraße 50

68229 Mannheim, Germany

T +49 621 486-2238

info.de@alixis.com

**www.alixis.de**

